

# Barudan

COMPUTER MONOGRAM MACHINE

MODEL **BEAT 802**  
(U.S.A.)

## PARTS LIST

**BARUDAN CO., LTD.**

ADDRESS 20-TSUKAGOSHI, JOSUJI  
ICHINOMIYA-CITY, AICHI-PREF.  
JAPAN

TEL. <0586>77-0404  
TELEX 4573268 BARUNA J  
CABLE BARUNA ICHINOMIYA



# BEAT-802 (U. S. A)

## PARTS LIST

### INDEX

ITEM No.	Page No.
Machine layout .....	1
①Fram and Table assy .....	2
②Sewing head .....	4
③Needle bar • Take up lever mechanism .....	6
④Thread guide mechanism .....	8
⑤Jamp mechanism .....	10
⑥Color change mechanism .....	12
⑦Option .....	14
⑧Conecting mechanism .....	16
⑨Drive mechanism .....	18
⑩Pantograph drive mechanism I .....	20
⑪Pantograph drive mechanism (H) II .....	22
⑫Pantograph drive mechanism (V) III .....	24
⑬Contorol system .....	26
⑭Thread cutting mechanism I .....	28
⑮Thread cutting mechanism II .....	30
⑯Thread cutting mechanism III .....	32



Machine layout (PROFIT-802)

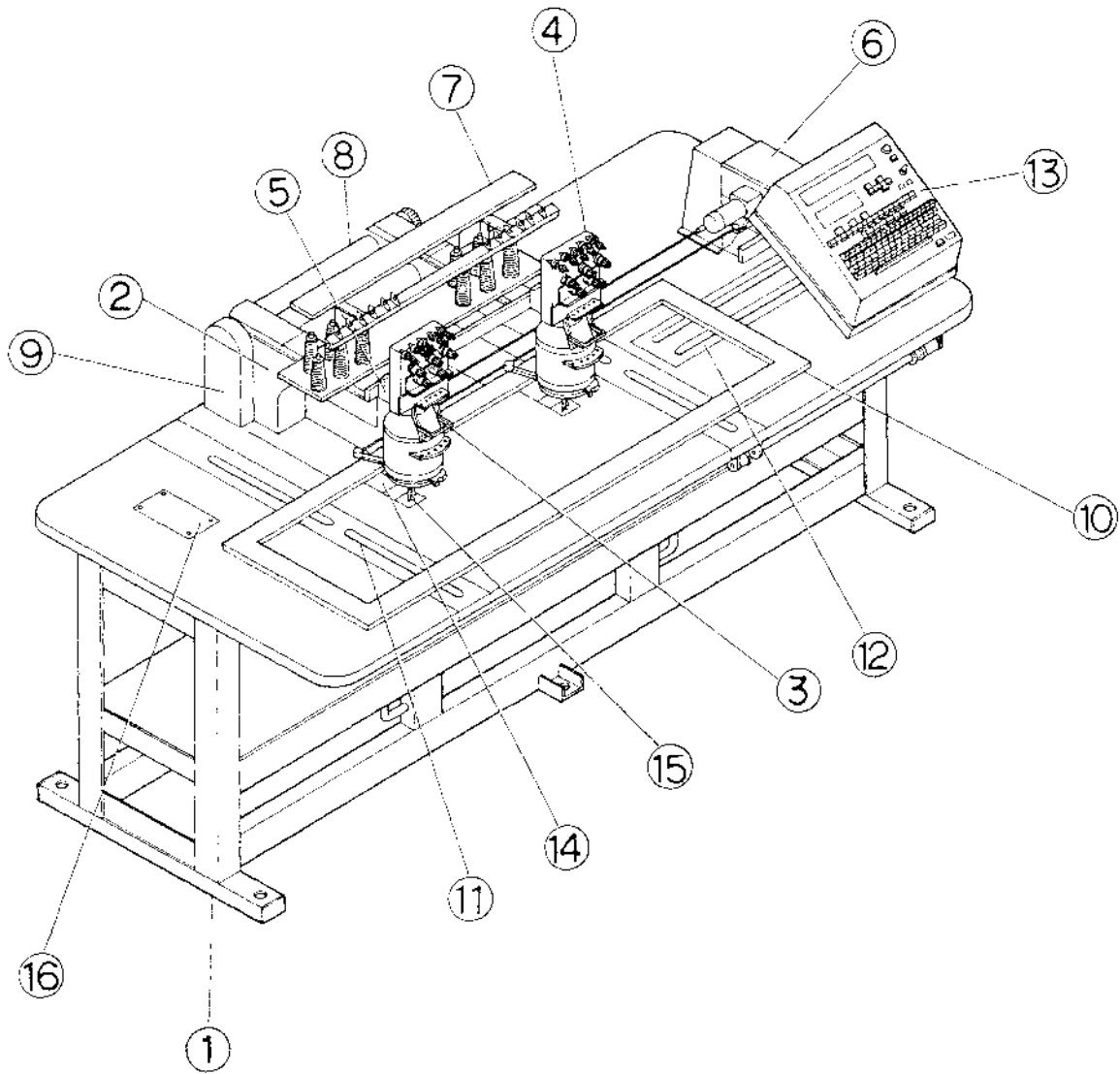

① Frame and Table assy

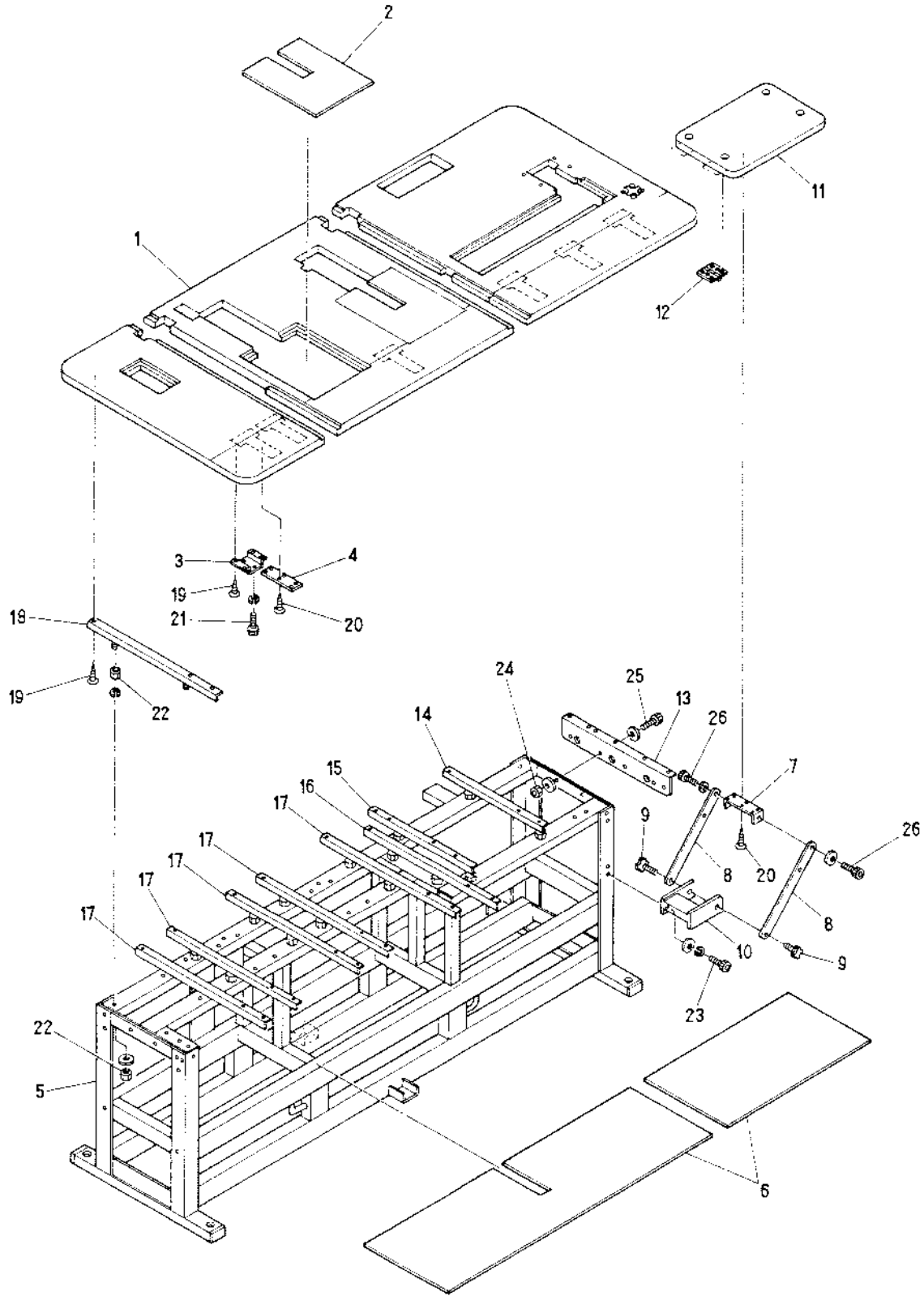



① Frame and Table assy

ITEM	PART No	LIST No	DESCRIPTION	QTY	REMARK
1	1602U03	KU151828	Table (Profit-802, 320×450)	1	
2	1358002	KG120682	Table cover	2	
3	1438A	MA140880	Support table bracket	6	
4	1499A	MA140690	Support table (Big)	6	
5	1602U02	KU181822	Frame (Profit-802, 320×450)	1	
6	15H7000	KU151770	Shelf board (Profit-702, 320×450)	1	
7	1474A	MA140740	Stay fixing bracket	1	
8	1478A	MA140780	Stay	2	
9	81208	AG012008	Knob bolt M10 L=20	2	
10	1476A	MA140760	Sub table bracket	1	
11	1475A	MA140750	Sub table	1	
12	1499A00	MA140960	Sub table hinge B-1-4	2	
13	1280U00	KU120800	Table support	1	
14	1284C01	KC120841	Table support (475L)	2	
15	1455U00	KU140550	Table support	1	
16	1457A	MA140570	Table support (650L AT-106)	3	
17	1453A	MA140530	Table support No.1	2	
18	1458A	MA140580	Table support	1	
19			Screw M5×25		
20			Wood screw M5.1×32		
21			Hex. socket bolt M8×15		
22			Hex. nut 3/8		
23			Hex. socket bolt M8×20		
24	1191C	KC110910	Side cover for frame (R)	1	
25			Hex. socket bolt M6×20		
26			Hex. socket bolt M8×30		
27			Hex. socket bolt M8×8		

## ② Sewing head

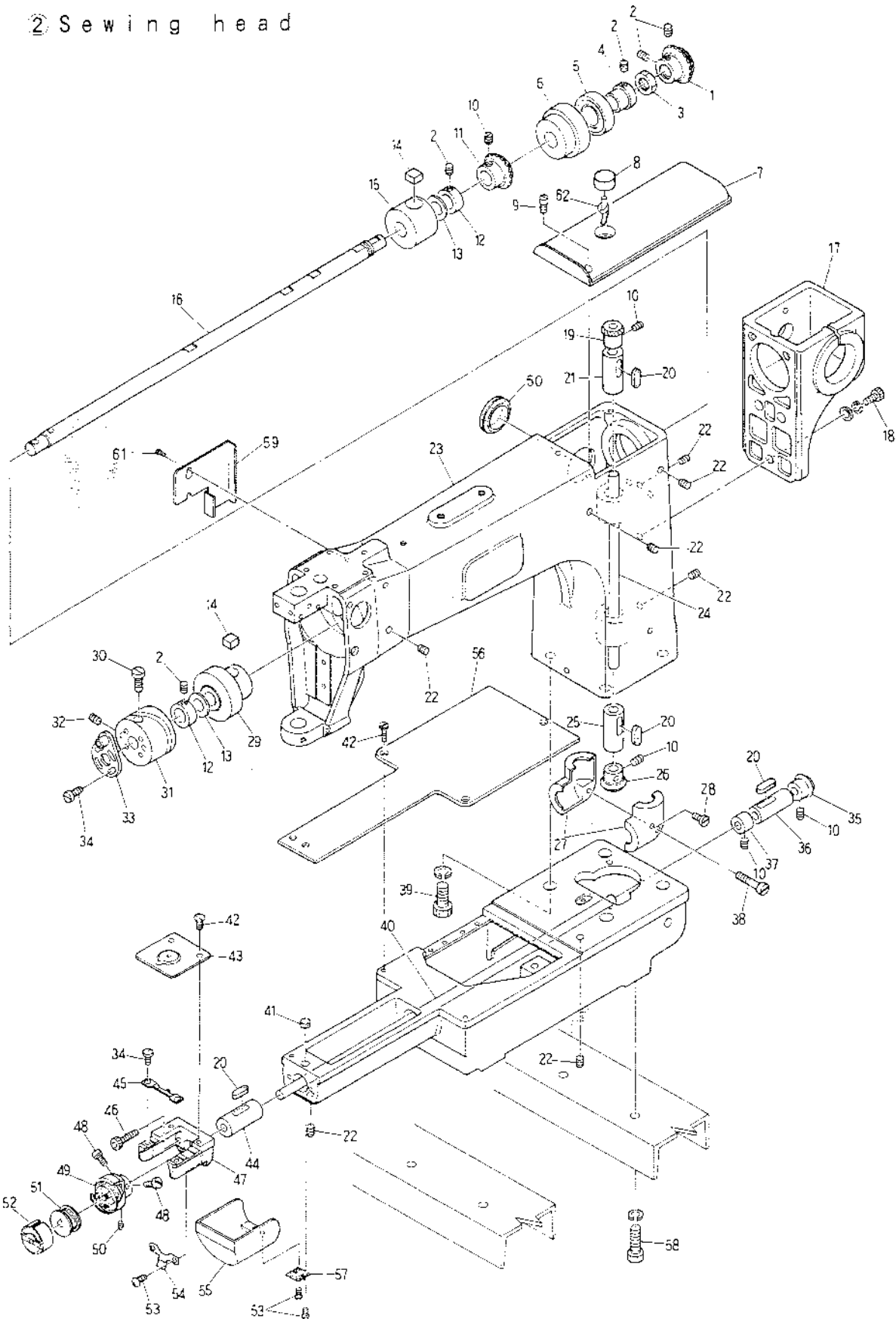



## ② Sewing head

ITEM	PART No.	LIST No.	DESCRIPTION	QTY	REMARK
1	2210L00	KL 2 2 0 1 0 0	Top shaft gear	1	
2			Hex. socket set screw M2×8		
3	2211L00	KL 2 2 0 1 1 0	Top shaft adjust nut M4	1	
4	2209L00	KL 2 2 0 0 9 0	Top shaft bearing collar (Rear)	1	
5	91017	A 9 0 1 0 0 1 7	Bearing (6004ZZ)	1	
6	2204L00	KL 2 2 0 0 4 0	Top shaft bearing case	1	
7	2504L00	KL 2 5 0 0 4 0	Arm top cover	1	
8	2215L00	KL 2 2 0 1 5 0	Oil felt D	1	
9			Screw M4X10		
10			Screw (SM1/4 40×4)		
11	2219F	KF 2 2 0 1 3 0	Bevel gear (Top shaft)	1	
12	2235L00	KL 2 2 0 0 8 0	Top shaft collar	2	
13	2319P00	HP 2 3 1 3 9 0	Thrust washer	2	
14	2213L00	KL 2 2 0 1 3 0	Oil felt B	2	
15	2203L00	KL 2 2 0 0 3 0	Top shaft metal (Middle)	1	
16	2200L00	KL 2 2 0 0 0 0	Top shaft	1	
17	2114L00	KL 2 1 0 1 4 0	Arm gear case	1	
18			Hex. socket bolt M6×25		
19	2248F	KF 2 2 0 4 6 0	Bevel gear (Vertical shaft upper)	1	
20	2214L00	KL 2 2 0 1 4 0	Oil felt C	4	
21	2205L00	KL 2 2 0 0 5 0	Vertical shaft metal (upper)	1	
22			Hex. socket set screw M6×8		
23	2100L00	KL 2 1 0 0 0 0	SRE Assy Head 7		
	2101L00	KL 2 1 0 0 1 0	SRE Assy Head 5		
	2100L0T	KL 2 1 0 0 0 T	SRE Assy Head 7 (with thread cutter)		
	2101L0T	KL 2 1 0 0 1 T	SRE Assy Head 5 (with thread cutter)		
24	2201L00	KL 2 2 0 0 1 0	Vertical shaft	1	
25	2206L00	KL 2 2 0 0 6 0	Vertical shaft metal (Lower)	1	
26	2247F	KF 2 2 0 4 7 0	Bevel gear (Vertical shaft (Lower))	1	
27	2227F	KF 2 2 0 2 7 0	Gear cover set	1	
28			Screw (SM15/64 28×24)		
29	2202L00	KL 2 2 0 0 2 0	Top shaft metal (Front)	1	
30	2342F	KF 2 3 0 4 2 0	Cam set screw	1	
31	2341N00	KN 2 3 0 4 1 0	Take up lever cam G	1	
32			Screw (SM15/64 28×10)		
33	2343N00	KN 2 3 0 4 3 0	90° Clamping	1	
34	91207	A 9 0 1 2 0 0 7	Screw	8	
35	2245F	KF 2 2 0 4 5 0	Bevel gear (Bottom shaft)	1	
36	2207L00	KL 2 2 0 0 7 0	Bottom shaft metal (Rear)	1	
37	2229F	KF 2 2 0 2 9 0	Bottom shaft collar	1	
38			Screw (SM3/62 20×38)		
39			Hex. socket bolt M12×35		
40	2221C	KC 2 2 0 2 1 0	Bottom shaft	1	
41	2212L00	KL 2 2 0 1 2 0	Oil felt A	1	
42	2500F	KF 2 5 0 0 0 0	Needle plate set screw (SM11/64 40×7)	2	





③ Needle bar • Take up lever mechanism

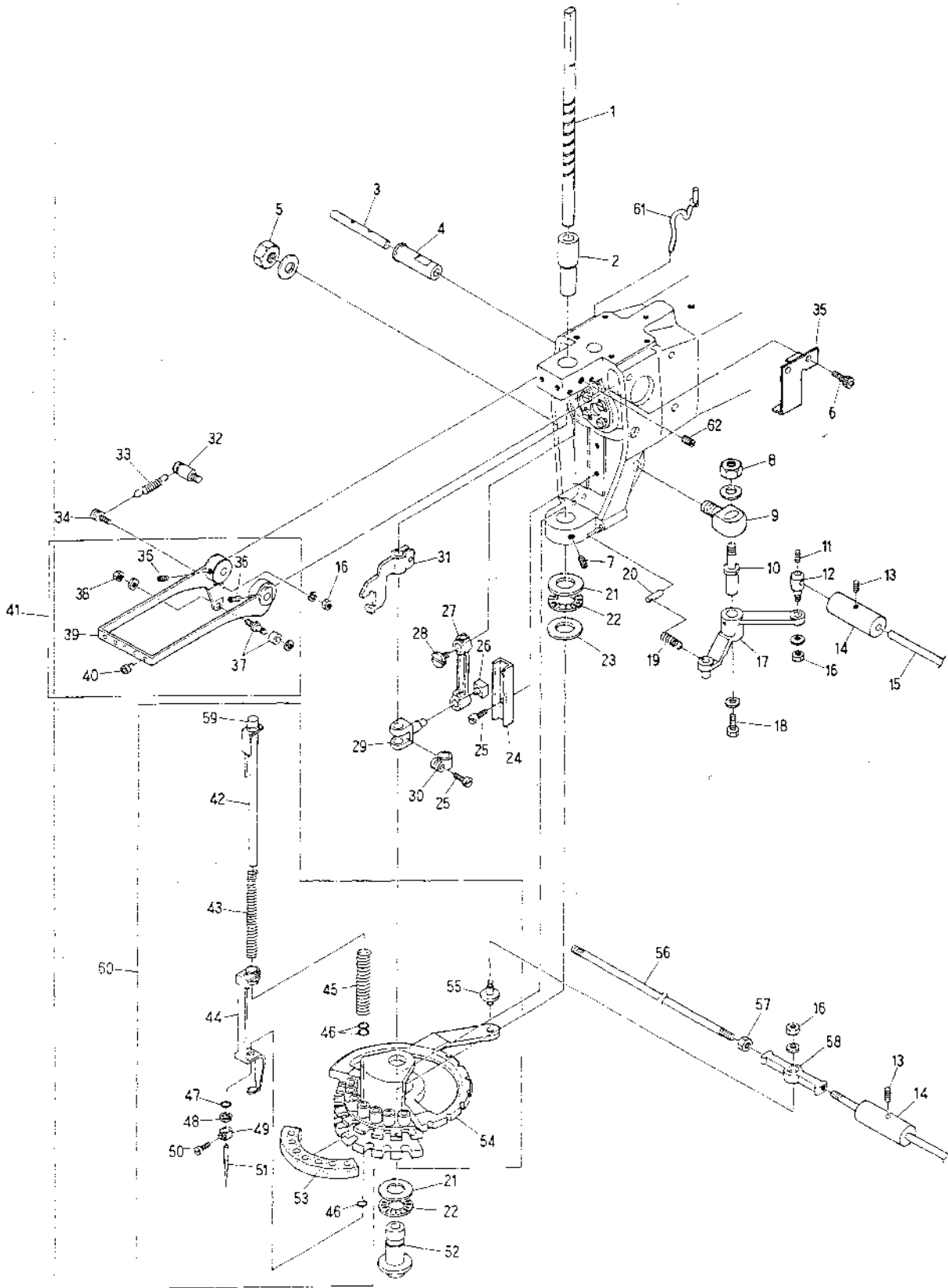

## ③ Needle bar • Take up lever mechanism

(N=needle qty)

ITEM	PART No.	LIST No.	DESCRIPTION	Q'TY	REMARK
1	2303L00	KL 2 3 0 3 0 0	Driving shaft	1	
2	2332F	KF 2 3 0 3 2 0	Driver shaft upper metal	1	
3	2351F02	KF 2 3 0 5 1 2	Take up lever shaft	1	
4	2352F01	KF 2 3 0 5 2 1	Take up lever metal	1	
5			Hex. nut M10		
6			Hex. socket bolt M4 × 8		
7			Hex. socket set screw (steel globe) M5 × 0.75 × 6		
8			Hex. nut M8		
9	2385F	KF 2 3 0 6 5 0	Lock lever bracket	1	
10	2363F	KF 2 3 0 6 3 0	Lock lever shaft	1	
11			Hex. socket set screw M4 × 6		
12	2364F	KF 2 3 0 5 4 0	Lock connection rod clamp	1	
13			Hex. socket set screw M5 × 5		
14	3338FC1	KF 3 3 0 3 8 1	Lock bar hand grip	1	
15	3341C	KC 3 3 0 4 1 0	Lock connecting rod (2M)	3	
16			Hex. nut M4		
17	2381G	KG 2 3 0 6 1 0	US Lock lever	1	
18			Hex. bolt M5 × 10		
19	2386F01	KF 2 3 0 6 6 1	Lock lever spring	1	
20	2387F	KF 2 3 0 6 7 0	Lock lever spring pin	1	
21	91123	A 9 0 1 1 0 2 3	Thrust bearing (CS1528)	2	
22	91121	A 9 0 1 1 0 2 1	Thrust bearing (NTB-1528)	2	
23	91122	A 9 0 1 1 0 2 2	Thrust washer (AS-1528)	1	
24	2301P00	HP 2 3 1 3 1 0	Guide box	1	
25			Screw (SM9/64 40 × 8)		
26	2307P00	HP 2 3 1 3 7 0	Square ball	1	
27	2300P01	HP 2 3 1 3 0 1	Clank rod	1	
28	2345F	KF 2 3 0 4 5 0	90° Clank screw fork	1	
29	2309P00	HP 2 3 1 2 9 0	Needle bar driving	1	
30	2348F	KF 2 3 0 4 8 0	Needle shaft clamp	1	
31	2314L00	KL 2 3 0 1 4 0	Needle bar driver	1	
32	2302L00	KL 2 3 0 0 2 0	Take up lever spring shaft	1	
33	2303L00	KL 2 3 0 0 3 0	Take up lever spring	1	
34	2301L00	KL 2 3 0 0 1 0	Take up lever spring screw	1	
35	2317L00	KL 2 3 0 1 7 0	Oil core bracket	1	
36			Hex. socket set screw M5 × 6		
37	2350F	KF 2 3 0 5 0 0	Take up lever roller assy	1	
38			Hex. nut 7/32		
39	2307L00	KL 2 3 0 0 7 0	Take up lever (SRE-7)	1	
	2308L00	KL 2 3 0 0 8 0	Take up lever (SRE-5)	1	
40	2355F	KF 2 3 0 5 8 0	Ceramic thread guide SRE (7)	N × 1	
41	2319L00	KL 2 3 0 1 9 0	Take up lever assy SRE (7)	1	
	2320L00	KL 2 3 0 2 0 0	Take up lever assy SRE (5)	1	
42	2301F	KF 2 3 0 0 1 0	Needle bar assy	N × 1	





# ④ Thread guide mechanism

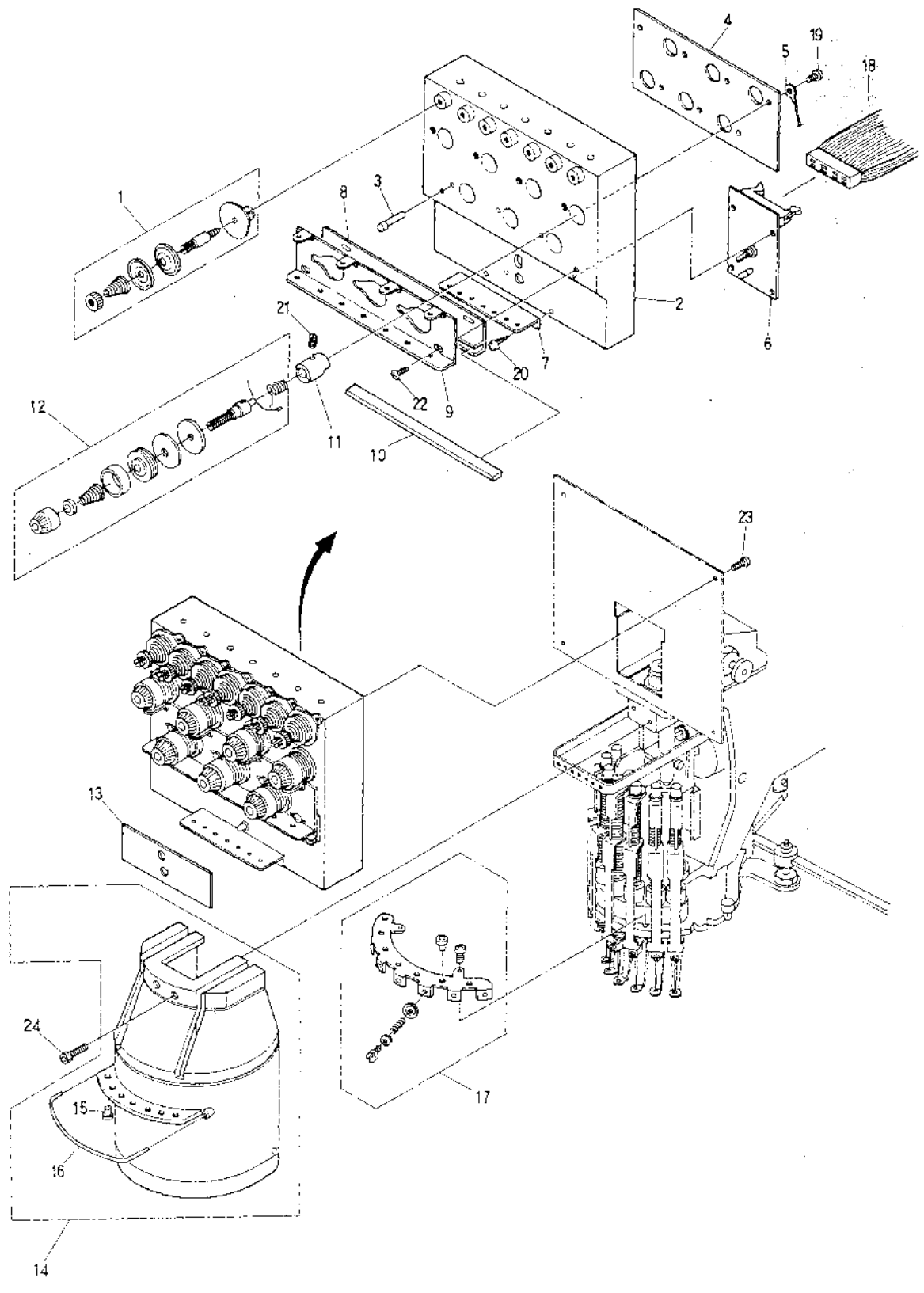



### ④ Thread guide mechanism

ITEM	PART No.	LIST No.	DESCRIPTION	QTY	REMARK
1	2442G	KG 2 4 1 0 2 0	Upper tension unit complete BS	5	
2	24B1P00	HP 2 4 1 1 1 0	Tension base (T)	1	
3	24B0P00	HP 2 4 1 1 8 0	Upper thread detection pin	5	
4	24D1P01	HP 2 4 1 3 7 1	Tension earth plate (S)	1	
5	24D9P00	HP 2 4 1 3 9 0	Tension earth cable	1	
6	85C0150	E B Y 0 0 1 5 0	3720 Head board	1	
7	24B9P00	HP 2 4 1 1 9 0	Second thread guide plate (T)	1	
8	24E5P00	HP 2 4 1 4 5 0	Thread guide felt fixing plate (T)	1	
9	24E7P00	HP 2 4 1 1 7 0	First thread guide (T)	1	
10	24E7P00	HP 2 4 1 4 7 0	Thread guide felt (T)	1	
11	24E5P00	HP 2 4 1 1 5 0	Tension base (with screw)	5	
12	24E1P00	HP 2 4 1 4 1 0	Dial type tension unit complete	5	
13	24E3P00	HP 2 4 1 4 3 0	Tension base label	1	
14	2500L00	KL 2 5 0 0 1 0	Sewing head cover (T)	1	
15	2433F01	KF 2 4 0 9 3 1	Thread guide $\phi 11$ (Alumina)	5	
16	8558P01	HP 2 5 0 5 8 1	Sewing head cover thread guide	1	
17	2505P00	HP 2 5 0 0 5 0	Thread end trap assy (UF)	1	
18	5142U00	KU 5 1 0 4 2 0	Flat cable AT-792 (S-4300×1.00×2)	1	
19			Pan screw M3×4		
20			Tapping screw M3.5×8		
21			Set screw (SM11/64 40×5.5)		
22			Truss screw M4×6		
23			Pan screw M4×10		
24			Hex. socket bolt M5×10		

⑤ Jamp mechanism

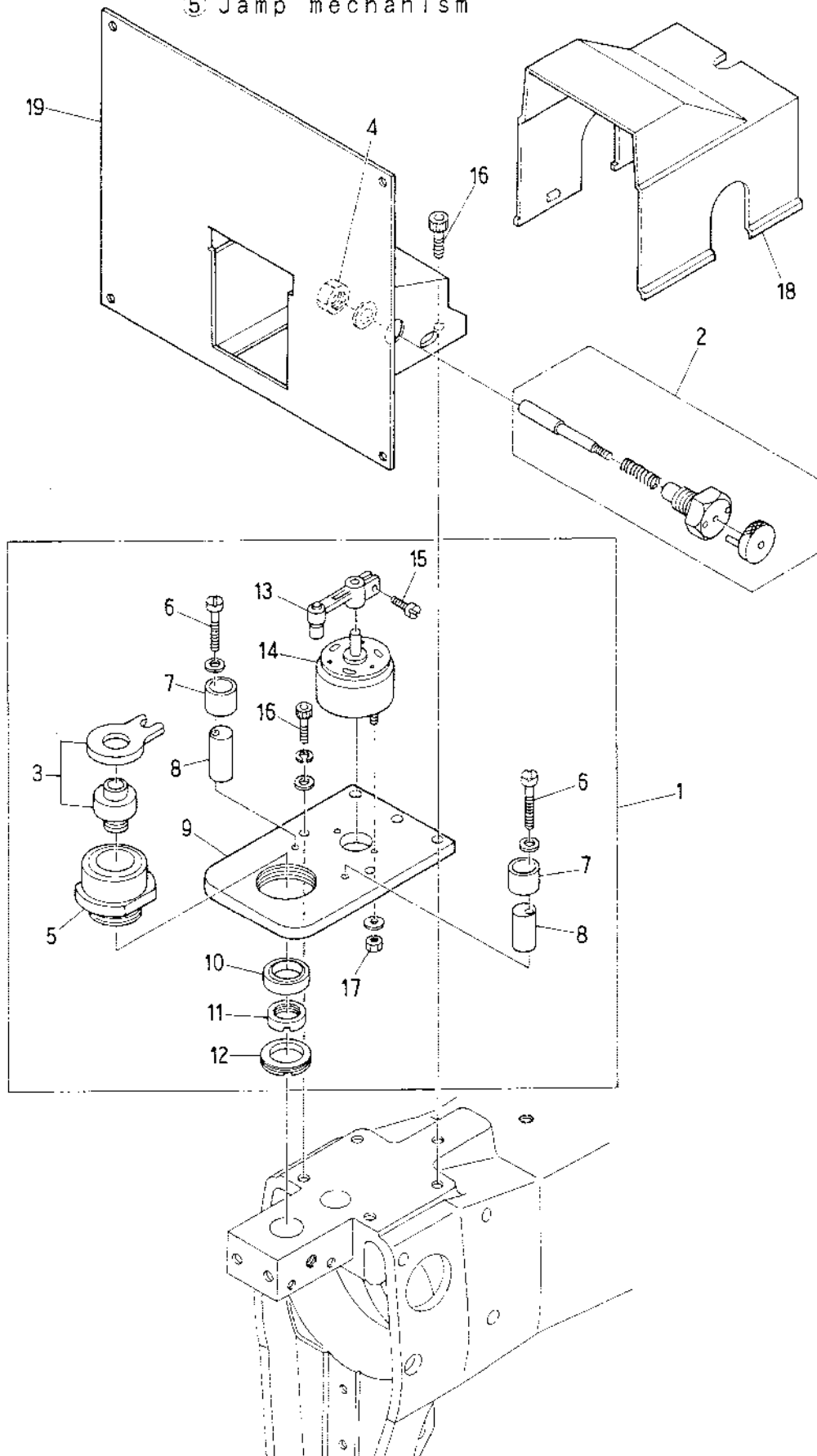

## ⑤ Jamp mechanism

ITEM	PART No	LIST No	DESCRIPTION	QTY	REMARK
1	2402P00	HP 2 4 0 0 2 0	Jamping set (ESRH)	1	
2	2439F	KF 2 4 0 0 3 0	Canceled pin Assy	1	
3	2420F00	KF 2 4 0 2 0 0	Rotor lever set	1	
4			Hex. nut M12		
5	2445F	KF 2 4 0 4 5 0	Rotor case	1	
6			Screw M3×25		
7	2449F	KF 2 4 0 4 9 0	Stopper eccentric cover	2	
8	2448F	KF 2 4 0 4 8 0	Stopper eccentric	2	
9	2303P00	HP 2 3 1 3 3 0	Solenoid base	1	
10	61009	A 8 0 1 0 0 0 9	Bearing (SSA-2015H)	1	
11	2447F	KF 2 4 0 4 7 0	Ring nut (S)	1	
12	2448F	KF 2 4 0 4 8 0	Ring nut (L)	1	
13	2442F	KF 2 4 0 4 2 0	Rotor lever	1	
14	2461F	KF 2 4 0 6 1 0	Rotary solenoid (SER25-35)	1	
15			Screw (SM9/64 40×8)		
16			Hex. socket bolt M5×15		
17			Hex. nut M3		
18	2401P00	HP 2 4 1 2 1 0	Tension cable cover	1	
19	2463P00	HP 2 4 1 1 3 0	Tension base (5)	1	
	2464P00	HP 2 4 1 1 4 0	Tension base (7)	1	

# ⑥ Color change mechanism

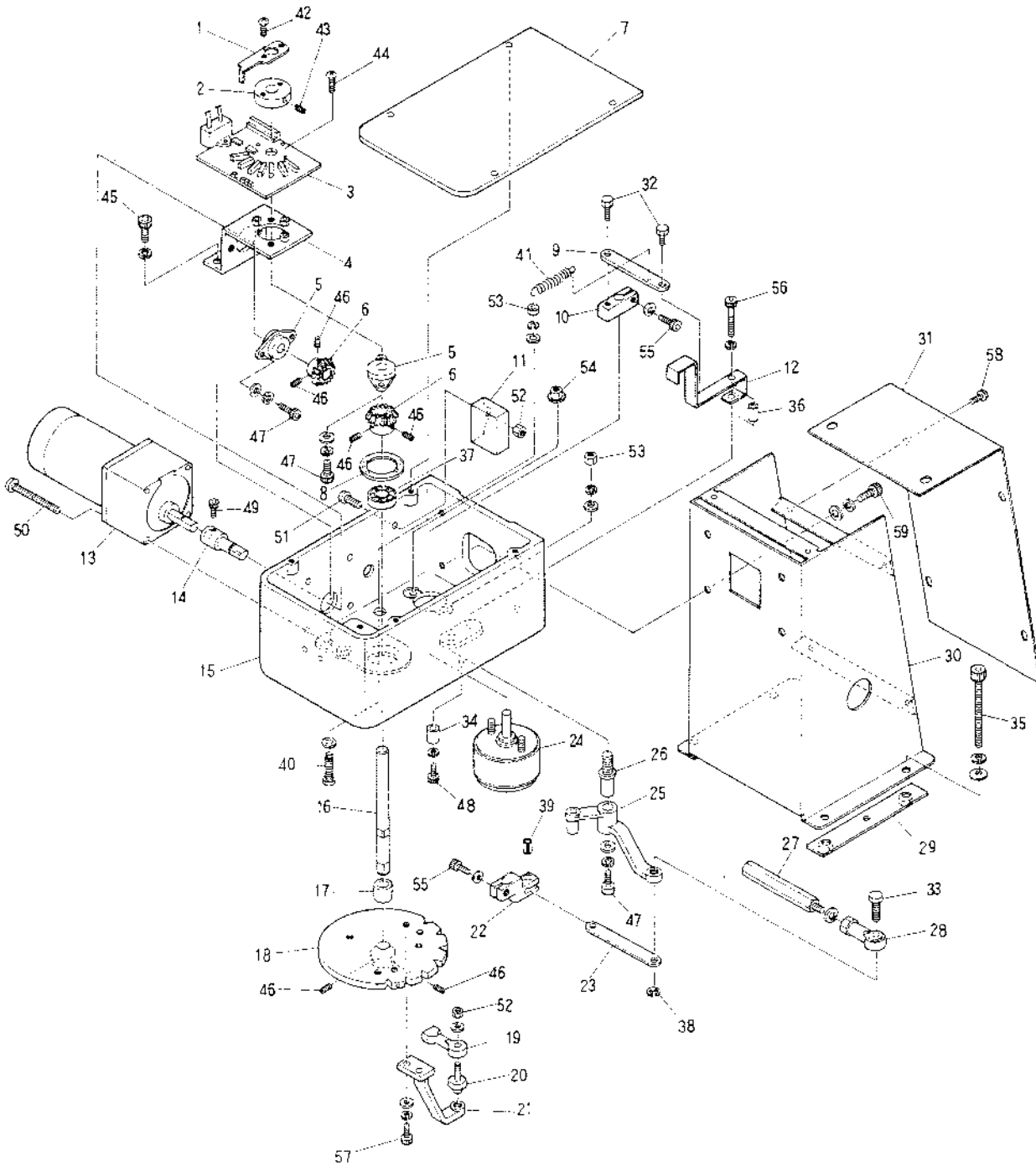

⑥ Color change mechanism

ITEM	PART No.	LIST No.	DESCRIPTION	QTY	REMARK
1	3328H01	HH 3 3 0 2 5 1	Detection plate	1	
2	3317C	KC 3 3 0 1 7 0	Plate collar	1	
3	55T0100	EBN 0 0 6 6 0	SDU color change board (7000 4100)	1	
4	33J1UCG	KU 3 3 1 9 1 0	Turret drive base	1	
5	91149	A 9 0 1 1 0 4 9	FYH. oilless pyrc 80 (80FL-10)	2	
6	3362H	HH 3 3 0 6 2 0	1M25T straight miter bevel	2	
7	33H4UC0	KU 3 3 1 7 4 0	Lock detection plate (Drive plate)	1	
8	912F0	A 9 0 1 2 1 5 0	Thrust washer (TW1530)	1	
9	33J4P00	HP 3 3 1 9 4 0	Lock detactive plate (Drive plate)	1	
10	33J6P00	HP 3 3 1 6 9 0	Lock detactive plate (Drive lever)	1	
11			Condenser (3381H accessory)	1	
12	33J3UCG	KU 3 3 1 9 3 0	Lock detactive plate	1	
13	3381H	HH 3 3 0 8 1 0	Gear motor RM-F6A5PCS-AS-180	1	
14	33F7P00	HP 3 3 1 5 7 0	Gear motor shaft	1	
15	33J0UC0	KU 3 3 1 9 0 0	Turret control box	1	
16	33F8P00	HP 3 3 1 5 8 0	Needle turning shaft	1	
17	33F9P00	HP 3 3 1 5 9 0	Turn table adjusting collar	1	
18	3315G	KG 3 3 0 1 5 0	US Control turning plate	1	
19	91201	A 9 0 1 2 0 0 1	NMB RD4 020R	1	
20	33G6P00	HP 3 3 1 6 6 0	Turret plate joint pin	1	
21	33F2U00	HP 3 3 1 5 2 0	Turret turn table lever	1	
22	33F5P0C	HP 3 3 1 5 5 0	Lock solenoid lever	1	
23	33G0P0C	HP 3 3 1 5 0 0	Lock lever link	1	
24	95611	A 9 0 5 6 0 1 1	Rotary solenoid 6SR25 27X3.4,9	1	
25	33F3P01	HP 3 3 1 5 3 1	Turret lock lever	1	
26	2363F	KF 2 3 0 6 3 0	Lock lever shaft	1	
27	3351C	KC 3 3 0 5 1 0	Hex. connecting bar (L)	1	
28	91202	A 9 0 1 2 0 0 2	NMB PR-6	1	
29	33H3U00	KU 3 3 1 7 3 0	Turret box stay fixing plate	2	
30	33H1U01	KU 3 3 1 7 1 1	Turret box fixing stay	1	
31	33H2U01	KU 3 3 1 7 2 1	Turret box fixing stay cover	1	
32	74CF3Q0	HQ 7 4 1 F 3 0	Bell crank bolt	2	
33	33F6P00	HP 3 3 1 5 6 0	Lock lever pin	1	
34	3367H	HH 3 3 0 6 7 0	Stopper eccentric	1	
35	2362F	KF 2 3 0 6 2 0	Lock lever roller	1	
36	33J5P00	HP 3 3 1 9 5 0	Lock detection plate (Turret shaft)	1	
37	91001	A 9 0 1 0 0 0 1	Bearing (8000z2)	1	
38	91255	A 9 0 1 2 0 5 5	E-ring $\phi 4$	1	
39	912B3	A 9 0 1 2 1 4 3	Spring $\phi 6$ L-12	1	
40	33H5U00	KU 3 3 1 7 5 0	Lock sub spring pin	1	
41	33H6U00	KU 3 3 1 7 6 0	Lock sub spring	1	
42			Screw M3 $\times$ 6		
43			Hex. socket set screw M3 $\times$ 8		
44			Screw M3 $\times$ 4		





⑦ Option

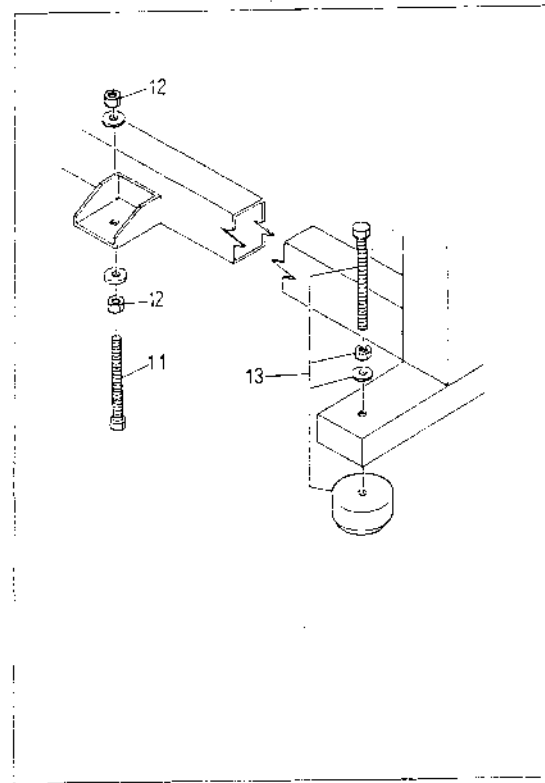
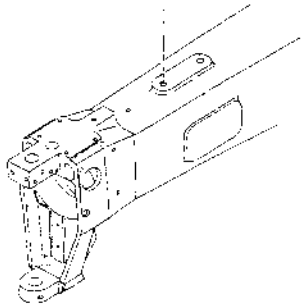
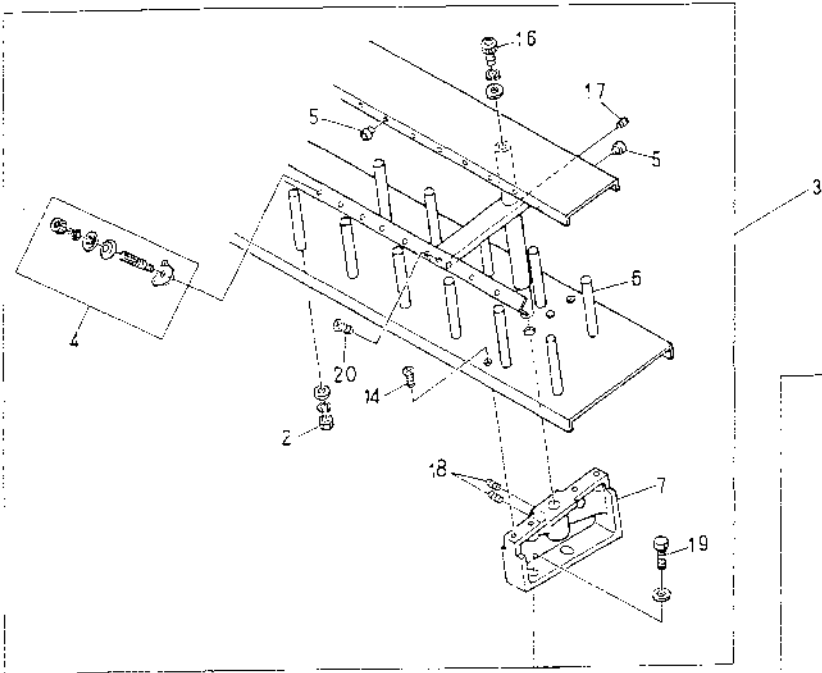
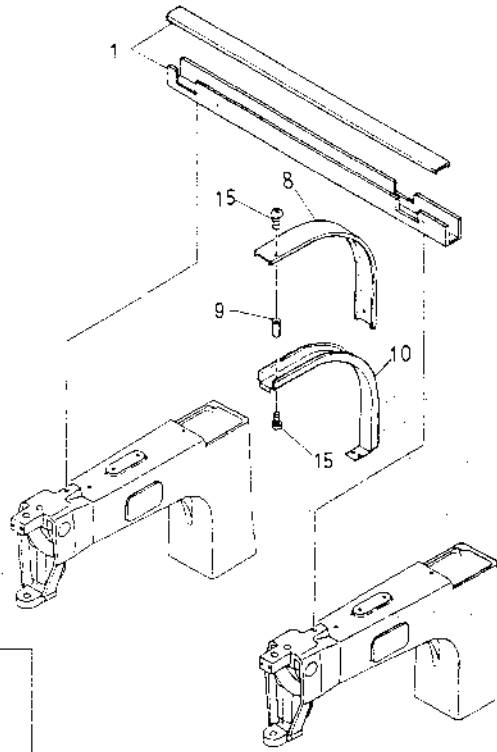





⑧ Conecting mechanism

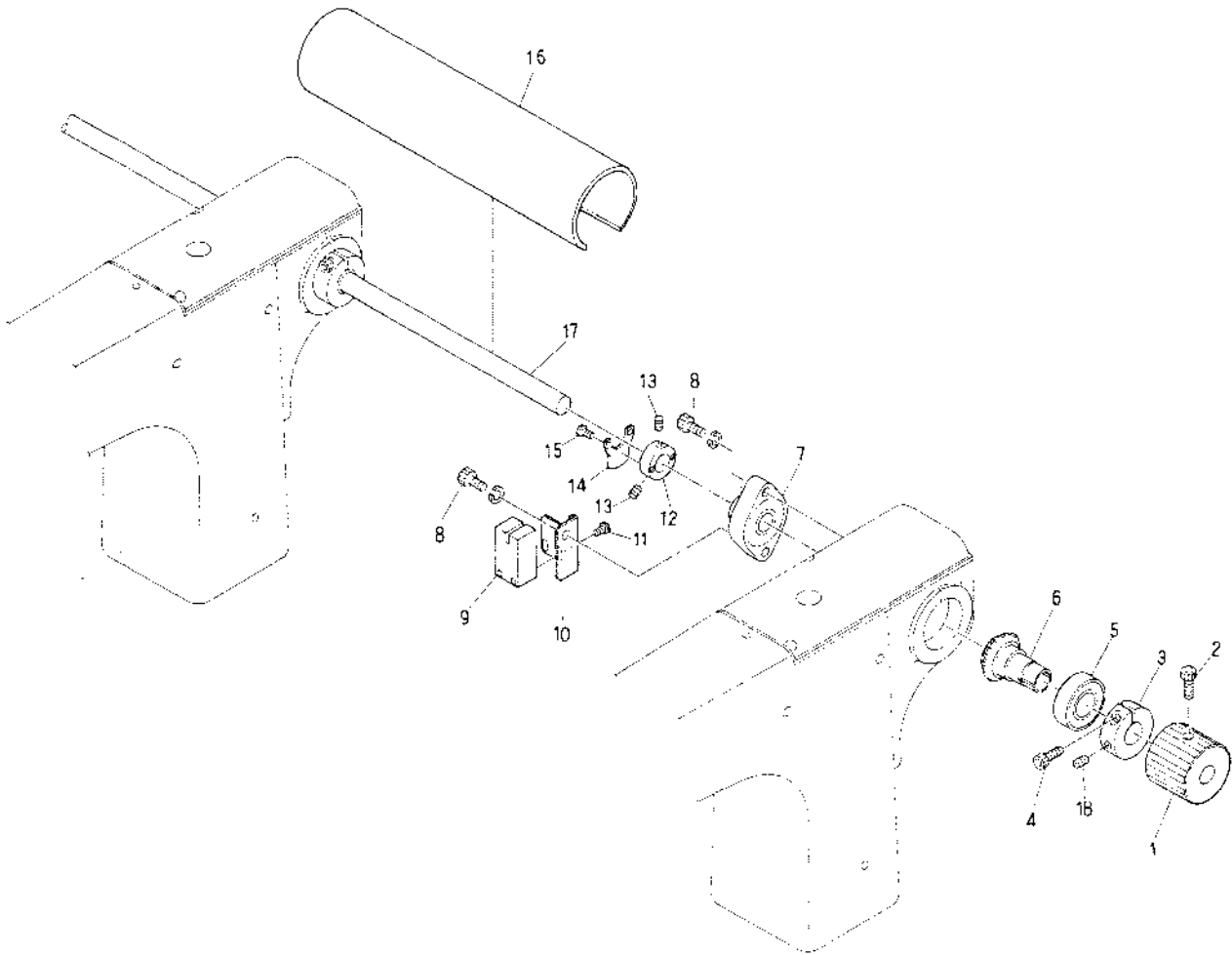



# 9 Drive mechanism

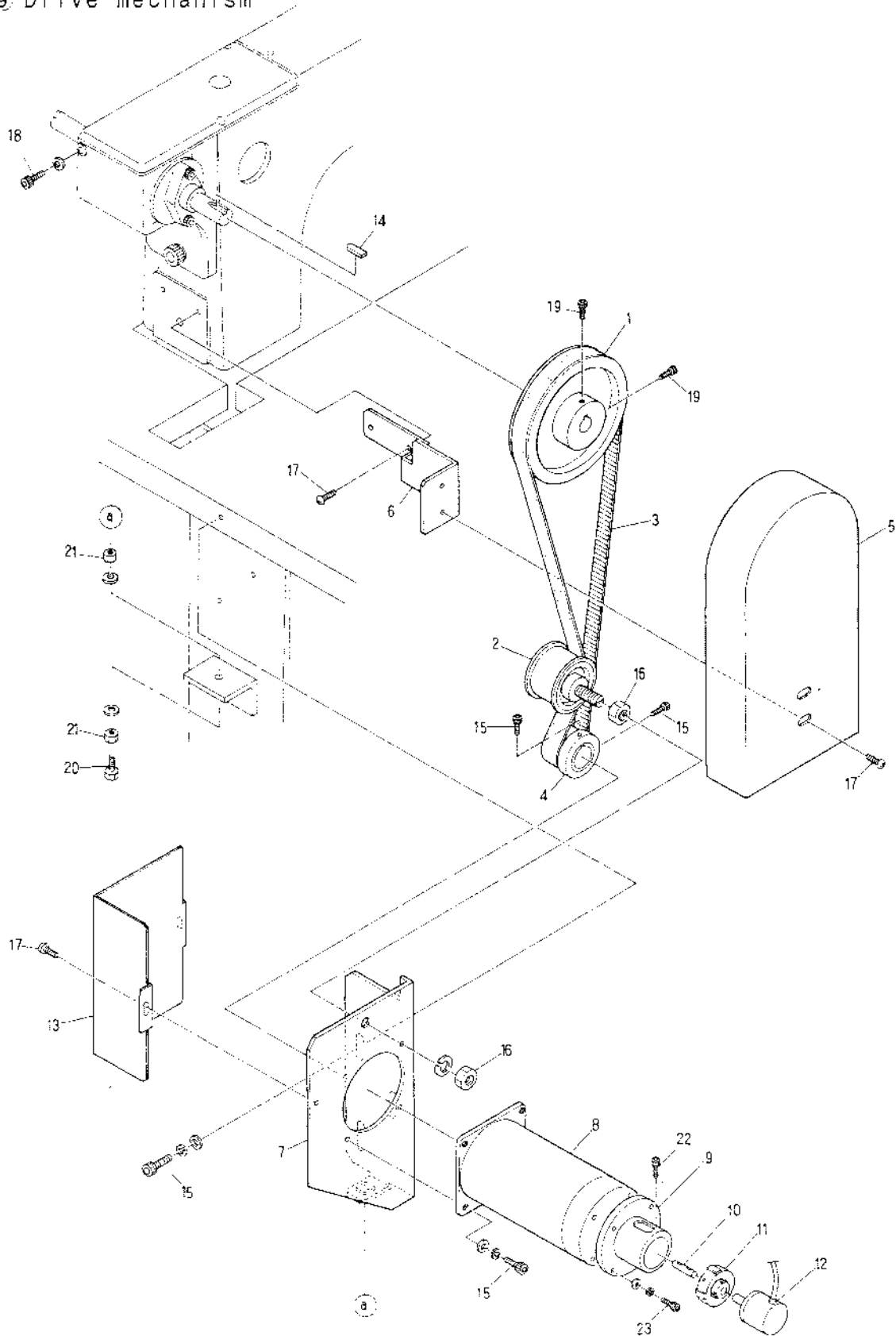

## ⑨ Drive mechanism

ITEM	PART No.	LIST No.	DESCRIPTION	QTY	REMARK
1	3189000	KU 3 1 2 7 3 0	Timing pully (P26-5M2-20-8F)	1	
2	93000	A 9 0 2 0 1 2 0	Flange idler (TPAKL 50)	1	
3	923B8	A 9 0 2 0 1 1 6	Timing belt (025-5M2-20)	1	
4	3182000	KU 3 1 2 7 2 0	Motor pully (P26-5M2-20-8F)	1	
5	3184001	KU 3 1 2 7 4 1	Belt cover	1	
6	3185001	KU 3 1 2 7 5 1	Belt cover bracket	1	
7	3110000	KU 3 1 0 1 0 0	Motor base (PROFIT-802)	1	
8	3113000	MT 3 1 0 1 3 0	DC Motor (37W-52700)	1	
9	3102000	MT 3 1 4 4 2 0	Encoder collar	1	
10	3101000	MT 3 1 4 4 1 0	Encoder shaft	1	
11	5124C	KC 5 1 0 2 4 0	ML 27-6 Rateral coupling	1	
12	5121000	MT 5 1 0 2 1 0	Position order (LBJ-007-600)	1	
13	3115002	KU 3 1 0 1 5 2	Pully cover	1	
14	3101000	KU 3 1 5 2 5 0	Key (5×5×28.5)	1	
15			Hex. socket bolt M8×15		
16			Hex. nut M10		
17			Truss screw M4×6		
18			Hex. socket bolt M6×60		
19			Hex. socket bolt M6×20		
20			Hex. bolt M8×45		
21			Hex. nut M8		
22			Hex. socket bolt M2×12		
23			Hex. socket bolt M4×12		

10 Pantograph drive mechanism I

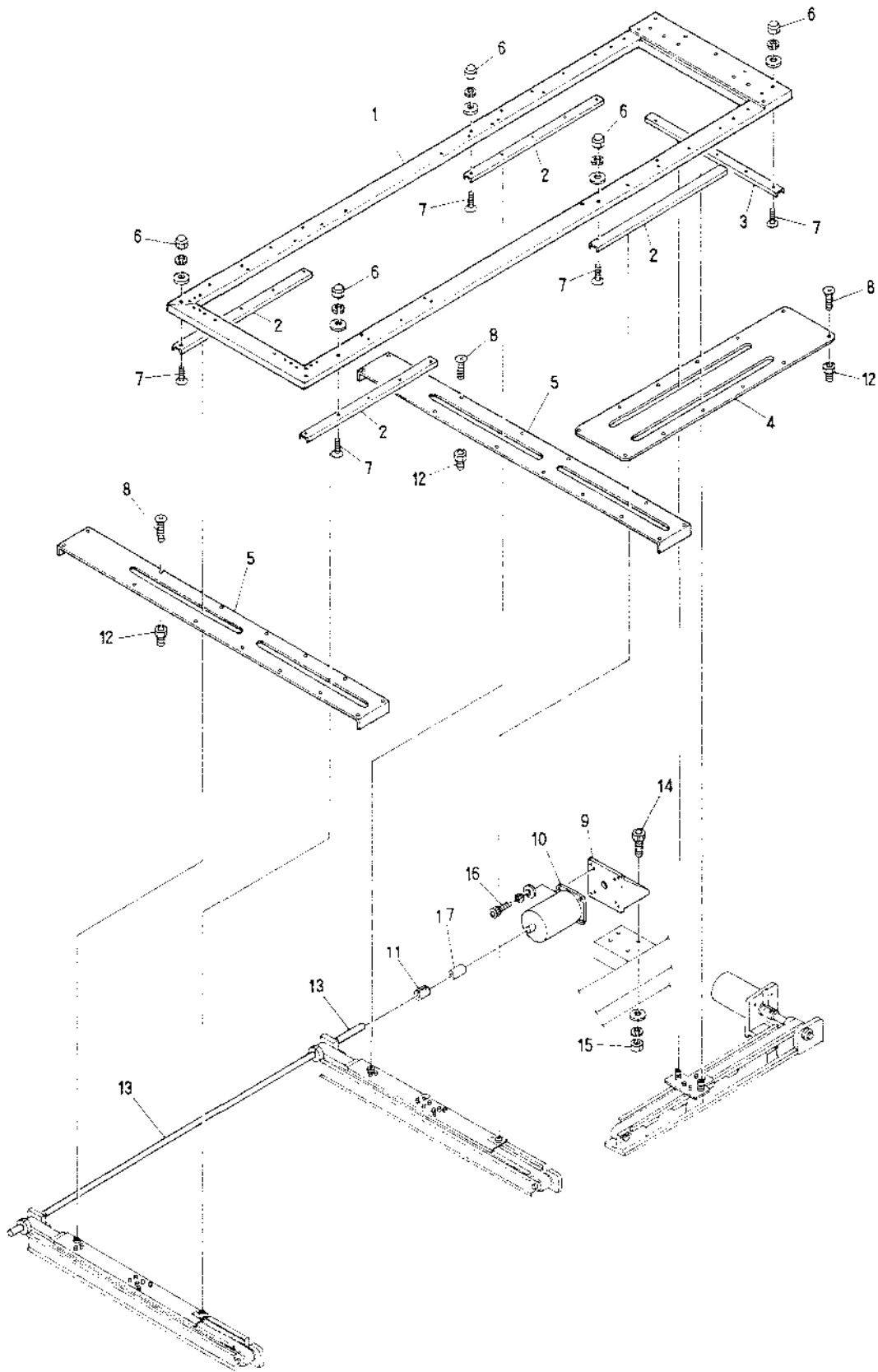



⑪ Pantograph drive mechanism (H) II

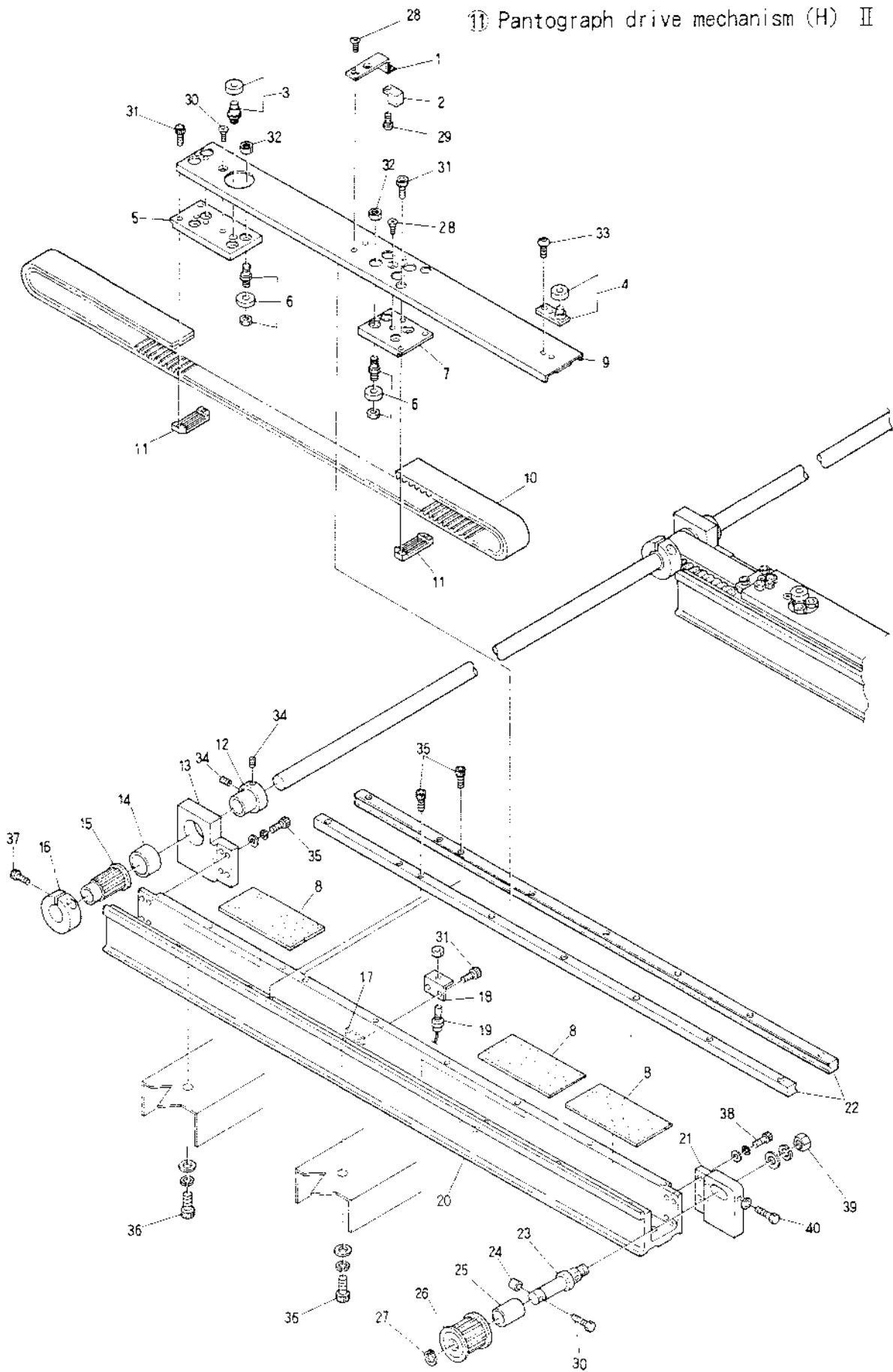



① Pantograph drive mechanism (H) II

ITEM	PART No.	LIST No.	DESCRIPTION	QTY	REMARK
1	483002	KU 4 6 0 3 4 2	H pantograph magnet bracket	1	
2	95226	A 9 0 5 2 0 2 6	Magnet M-102	1	
3	91008	A 9 0 1 0 0 0 8	Bearing (92572)(1953) 804	1	
4	48X600	HP 4 8 3 3 9 0	Bearing pin ASSY (H)	1	
5	48ST00	KN 4 8 2 8 7 0	H roller base (Rear)	1	
6	48T500	HP 4 8 2 9 5 0	Roller pin assy A	8	
7	48S800	KN 4 8 2 8 8 0	H roller base (Front)	1	
8	480601	KN 4 8 0 0 6 1	Rail base felt 100×38×6	3	
9	48Y400	KL 4 8 3 4 4 0	H member connecting channel (BEAT)	1	
10	92398	A 9 0 2 0 0 9 8	Timing belt 30GS5M2600	1	
11	48T400	HP 4 8 2 9 4 0	Timing belt rack (5M)	2	
12	48J7H	HH 4 8 1 8 7 0	Pulse motor connecting shaft collar	1	
13	48K100	KN 4 8 2 0 1 0	H guide rear pulley bracket	1	
14	91163	A 9 0 1 1 0 6 3	Needle bearing TLA 2016	1	
15	48T900	HP 4 8 2 9 9 0	Pantograph driving pulley (Rear) S5M	1	
16	48J8H	HH 4 8 1 9 8 0	Clamping φ19	1	
17	462700	KU 4 6 0 2 7 0	Plate nut M8	2	
18	482400	MT 4 6 0 2 4 0	RS-001 Bracket (V)	1	
	464601	KU 4 6 0 4 6 1	RS-001 Bracket (H.Rear)	1	
19	98224	A 9 0 5 2 0 2 4	Switch RS-001	2	
20	48Y000	KN 4 8 3 4 0 0	H guide rail base (BESR)	1	
21	48E300	KN 4 6 2 0 0 0	H guide front pulley bracket	1	
22	48Y500	KN 4 8 3 4 5 0	V guide rail (L-880)	2	
23	48J6H01	HH 4 8 1 8 9 1	Timing pulley shaft	1	
24	48L1H	HH 4 8 3 1 1 0	Timing pulley shaft bolt cap	1	
25	91179	A 9 0 1 1 0 7 9	Needle bearing TA-1225	1	
26	48T800	HP 4 8 2 9 8 0	Pantograph driving pulley (Front) S5M	1	
27	91252	A 9 0 1 2 0 5 2	E-ring (φ10)	1	
28			Flush screw M4×6		
29			Screw M3×6		
30			Hex. bolt M4×40		
31			Hex. socket bolt M3×8		
32			Hex. nut M5		
33			Button bolt M4×6		
34			Hex. socket set screw M5×8		
35			Hex. socket bolt M4×15		
36			Hex. socket bolt M8×20		
37			Hex. socket bolt M5×20		
38			Hex. socket bolt M4×18		
39			Hex. nut M5		
40			Hex. bolt M4×25		

⑫ Pantograph drive mechanism (V) III

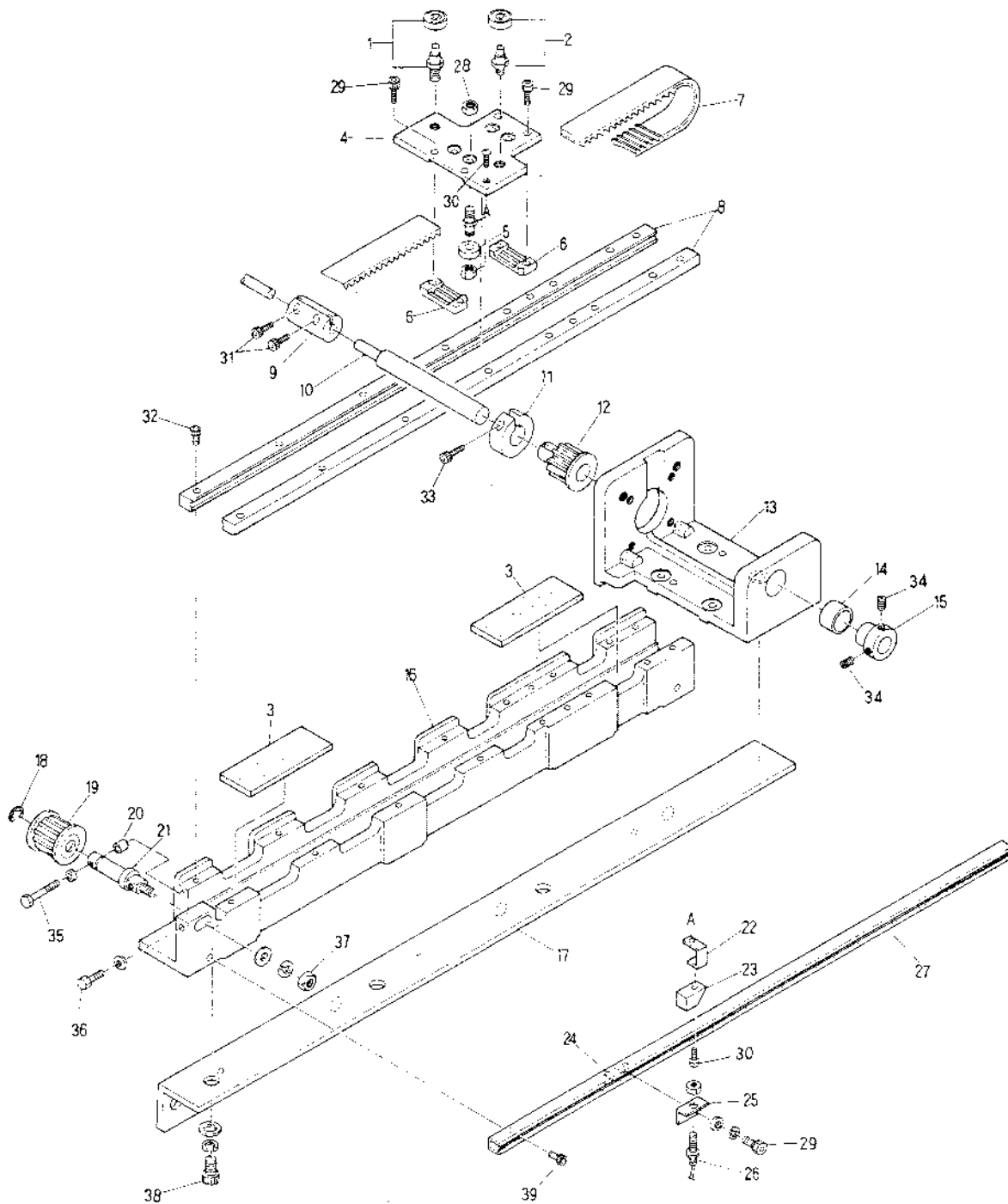

⑫ Pantograph drive mechanism (V) III

ITEM	PART No.	LIST No.	DESCRIPTION	QTY	REMARK
1	48V3PC1	HP 4 8 8 1 1 1	Bearing pin ASSY B	1	
2	48V3PC0	HP 4 8 8 3 7 0	Bearing pin ASSY	1	
3	48V8N01	KN 4 8 0 0 8 1	Rail base felt 100×38×5	2	
4	48V8U00	KU 4 8 3 1 8 0	V roller base (EM 30)	1	
5	48T5PC0	HP 4 8 2 9 5 0	Roller pin assy A	4	
6	48T4PC0	HP 4 8 2 9 4 0	Timing belt rack (5M)	2	
7	92G88	A 9 0 2 0 0 9 8	Timing belt 30CSEM2000	1	
8	48T1PC0	HP 4 8 2 9 1 0	V guide rail (L=1080)	2	
9	48J3H01	HH 4 8 1 9 3 1	Pulse motor coupling (804, 806)	1	
10	48I8U00	KU 4 8 0 1 8 0	V timing belt shaft (ATS04, 808, 808)	1	
11	48J8H	HH 4 8 1 9 8 0	Clamping φ19	1	
12	48T9P00	HP 4 8 2 9 9 0	Pantograph driving pulley (Rear) S5M	1	
13	47I0L00	KU 4 7 0 1 0 0	V pulse motor bracket	1	
14	91163	A 9 0 1 1 0 6 3	Needle bearing TLA 2010	1	
15	48J7H	HH 4 8 1 9 7 0	Pulse motor connecting shaft collar	1	
16	48I8U00	KU 4 8 0 1 3 0	V guide rail base	1	
17	4746U00	KU 4 7 0 4 6 0	V guide rail base bracket (480 stroke)	1	
18	91052	A 9 0 1 2 0 5 2	E ring (φ10)	1	
19	48T8P00	HP 4 8 2 9 8 0	Pantograph driving pulley (Front) S5M	1	
20	48L1H	HH 4 8 2 1 1 0	Timing pulley shaft bolt cap	1	
21	48J9H01	HH 4 8 1 9 9 1	Timing pulley shaft	1	
22	4832U01	KU 4 8 0 3 2 1	V pantograph origin point magnet bracket	1	
23	95226	A 9 0 5 2 0 2 6	Magnet M-102	1	
24	4627U00	KU 4 6 0 2 7 0	Plate nut M3	2	
25	4624T00	MT 4 6 0 2 4 0	RS-001 bracket (V)	2	
26	95224	A 9 0 5 2 0 2 4	Switch RS-001	2	
27	4836U00	KU 4 8 0 3 6 0	V pantograph origin point rail	1	
28			Hex. nut M5		
29			Hex. socket bolt M3×5		
30			Screw M3×6		
31			Hex. socket bolt M5×20		
32			Hex. socket bolt M4×15		
33			Hex. socket bolt M5×15		
34			Hex. socket set screw M3×3		
35			Hex. bolt M4×40		
36			Hex. bolt M4×25		
37			Hex. nut M3		
38			Hex. socket bolt M3×20		
39			Hex. socket bolt M4×8		

# 13 Control system

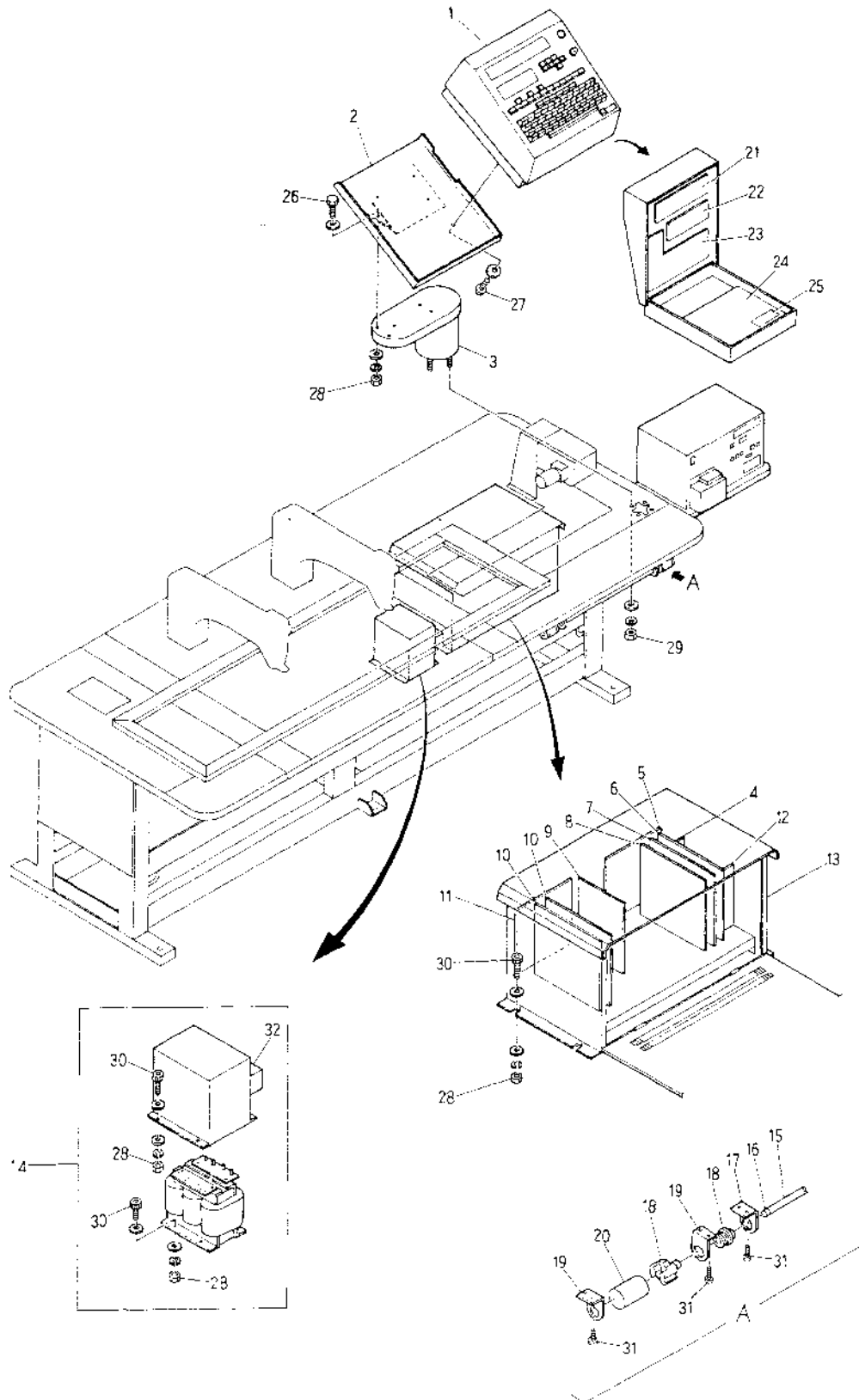

⑬ Control system

ITEM	PART No.	LIST No.	DESCRIPTION	QTY	REMARK
1	51R3CAU	EAN0018A1	SMT controller	1	
2	51C7T00	MT511270	SMT controller fixing base	1	
3	51C1U01	KU511211	Controller fixing pipe	1	
4	55T008C	EBN00590	SDU memory board (7020-2600)	1	
5	55T0020	EBN00580	SDU control mother board (7020-2300)	1	
6	55T0040	EBN00600	SDU memory mother board (7020-2500)	1	
7	55T0000	EBN00620	SDU control board (7020-2100)	1	
8	55T0070	EBN00630	SDU power board (7020-2200)	1	
9	55T0010	EBN00570	Power amp driver board (7020-2900)	1	
10	55T0080	EBN00640	Stepping motor driver (7020-2800)	1	
11	55T0000	EBN00560	SDU Driver mother board (7020-2700)	2	
12	55T0050	EBN00610	SDU System memory board (7020-2400)	1	
13	51R4UAC	EAN016A2	Driver SDU	1	
14	51J6CAU	EAN021A3	836 Transformer (1P)	1	
	51J7CAL	EAN022A3	836 Transformer (3P)	1	
	51J6CAU	EAN020A3	804 Transformer (1P)	1	
15	5318F	KF530180	Bar switch	1	
16	5317F	KF530170	Bar switch cap	2	
17	5324C00	KC530240	Bar switch bracket (S.Cylinder)	2	
18	5311F	KF530110	Push button switch MS320(Red)	1	
	5312F	KF530120	Push button switch MS310(Green)	1	
19	5323C00	KC530230	Bar switch bracket (L.Cylinder)	4	
20	5315F	KF530150	Push button switch cap	2	
21	55T0110	EBN00670	STX indicator (7020-7600)	1	
22	55T0120	EBN00680	SMT indicator (7020-7500)	1	
23	55T0130	EBN00690	SMT keyboard (7020-7300)	1	
24	55T0140	EBN00700	SMT controlboard (7020-7200)	1	
25	55T0150	EBN00710	SMT PSU board (7020-7210)	1	
26			Hex. bolt M3×15		
27			Hex. bolt M4×15		
28			Hex. nut M6		
29			Hex. nut M8		
30			Hex. socket bolt M6×30		
31			Screw M4×20		
32	EE06342	FA911090	DEAT Mofuse breaker	1	

14 Thread cutting mechanism I

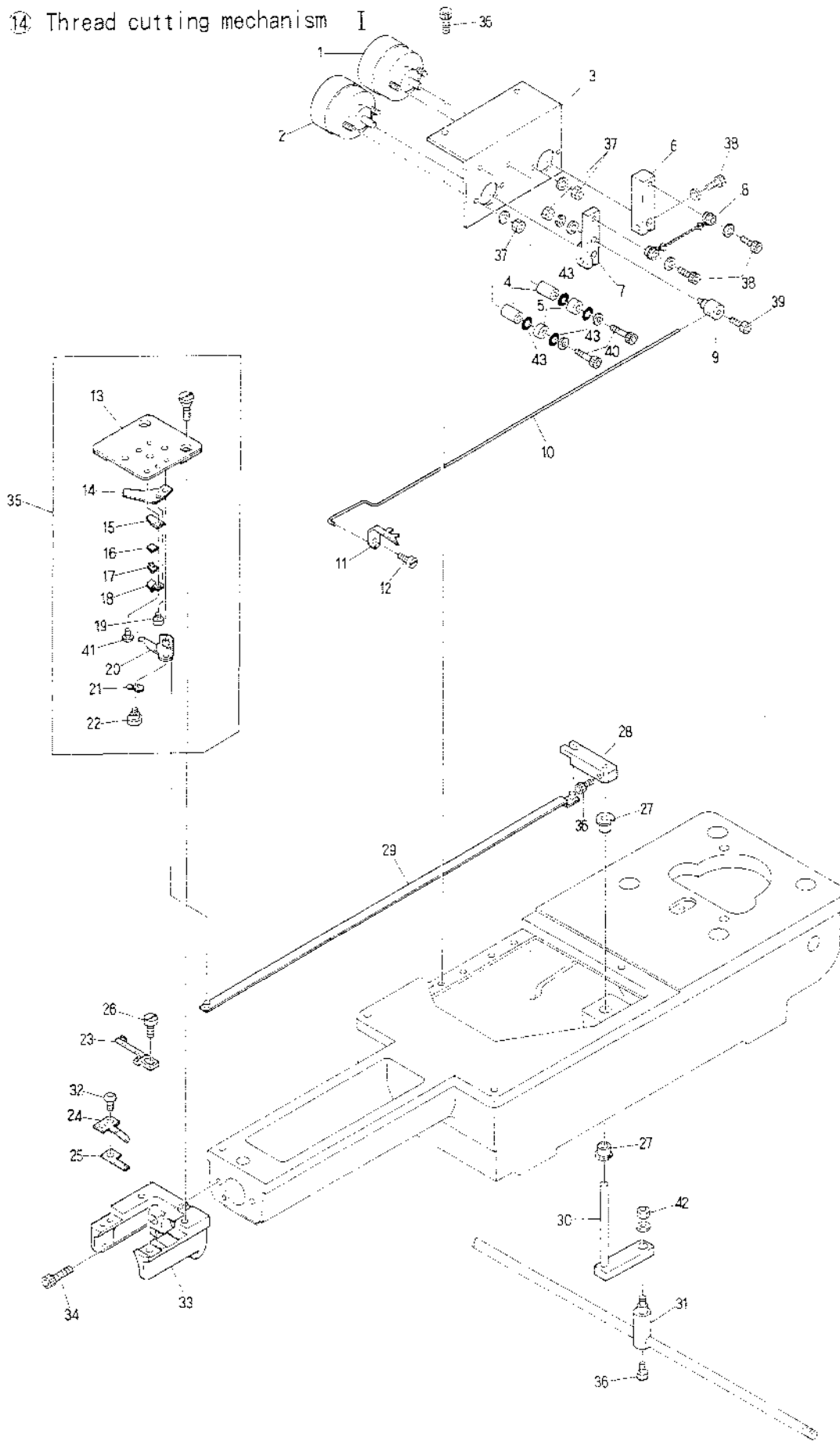

⑭ Thread cutting mechanism I

ITEM	PART No.	LIST No.	DESCRIPTION	QTY	REMARK
1	9C812	A 9 0 8 0 0 2	Rotary solenoid 3EL8X3.8.8	1	
2	9C808	A 9 0 8 0 0 8	Rotary solenoid 2ER20X3.8.8.	1	
3	27J00	KC 2 7 1 9 8 0	Solenoid stay	1	
4	27G8X01	KN 2 7 1 8 5 1	Stopper eccentric	2	
5	27G8N02	KN 2 7 1 8 6 2	Eccentric cover	2	
6	27J60	KC 2 7 1 9 5 0	Solenoid lever B	1	
7	27J40	KC 2 7 1 9 4 0	Solenoid lever A	1	
8	27J70	KC 2 7 1 9 7 0	Drive rope	1	
9	27A4C01	KC 2 7 1 9 4 1	Connecting clamp	1	
10	27A3C01	KC 2 7 1 9 3 1	Hook drive rod	1	
11	27A2C01	KC 2 7 1 9 2 1	Hook	1	
12	27A00	KC 2 7 1 0 0 0	Upper thread cutter turning shaft	1	
13	27B4C	KC 2 7 0 9 4 0	Needle plate	1	
14	27B60	KC 2 7 0 9 6 0	Fixed cutter	1	
15	27C2C	KC 2 7 1 2 2 0	Lower thread support stay (Upper)	1	
16	27C1C01	KC 2 7 1 2 1 1	Magic tape (Upper)	1	
17	27C0C01	KC 2 7 1 2 0 1	Magic tape (Lower)	1	
18	27B9C01	KC 2 7 1 1 8 1	Lower thread support stay (Lower)	1	
19	27B80	KC 2 7 0 9 8 0	Fixed cutter set screw	1	
20	27B50	KC 2 7 0 9 5 0	lower thread cutter	1	
21	91345	A 9 0 1 3 3 4 5	Wave washer (WW5)	1	
22	27B7C	KC 2 7 0 9 7 0	Lower thread cutter turret shaft	1	
23	27B4C01	KC 2 2 0 6 4 1	Bobbin case fixing plate	1	
24	2719N00	KN 2 7 1 8 9 0	Cutter fixing plate	1	
25	27C0N01	KN 2 7 1 6 0 1	Upper thread cutter	1	
26			Screw (SM11/54 40×7)	1	
27	91284	A 9 0 1 2 1 1 4	BU bush (MFC505-10FDD)	1	
28	27B2C	KC 2 7 1 1 2 0	Lower thread cutter drive lever (Upper)	1	
29	27A7C	KC 2 7 1 0 7 0	Lower thread cutter drive rod	1	
30	27B3C	KC 2 7 1 1 3 0	Lower thread cutter drive lever (Lower)	1	
31	28C4F	KF 2 3 0 8 4 0	Lock connecting bar clamp	1	
32			Hex. socket bolt M3×6	1	
33	2112L00	KL 2 1 0 1 2 0	Needle plate bracket (SRB-T)	1	
34			Hex. socket bolt M5×15	1	
35	27B8C	KC 2 7 1 1 8 0	Cylinder needle plate CMP	1	
36			Hex. socket bolt M4×8		
37			Hex. nut M3		
38			Hex. socket bolt M4×10		
39			Hex. socket bolt M3×5		
40			Hex. socket bolt M4×18		
41			Pan screw M3×3		
42			Hex. nut M4		
43	27P4N00	KN 2 7 2 5 4 0	O Ring LAPS	4	

15 Thread cutting mechanism II

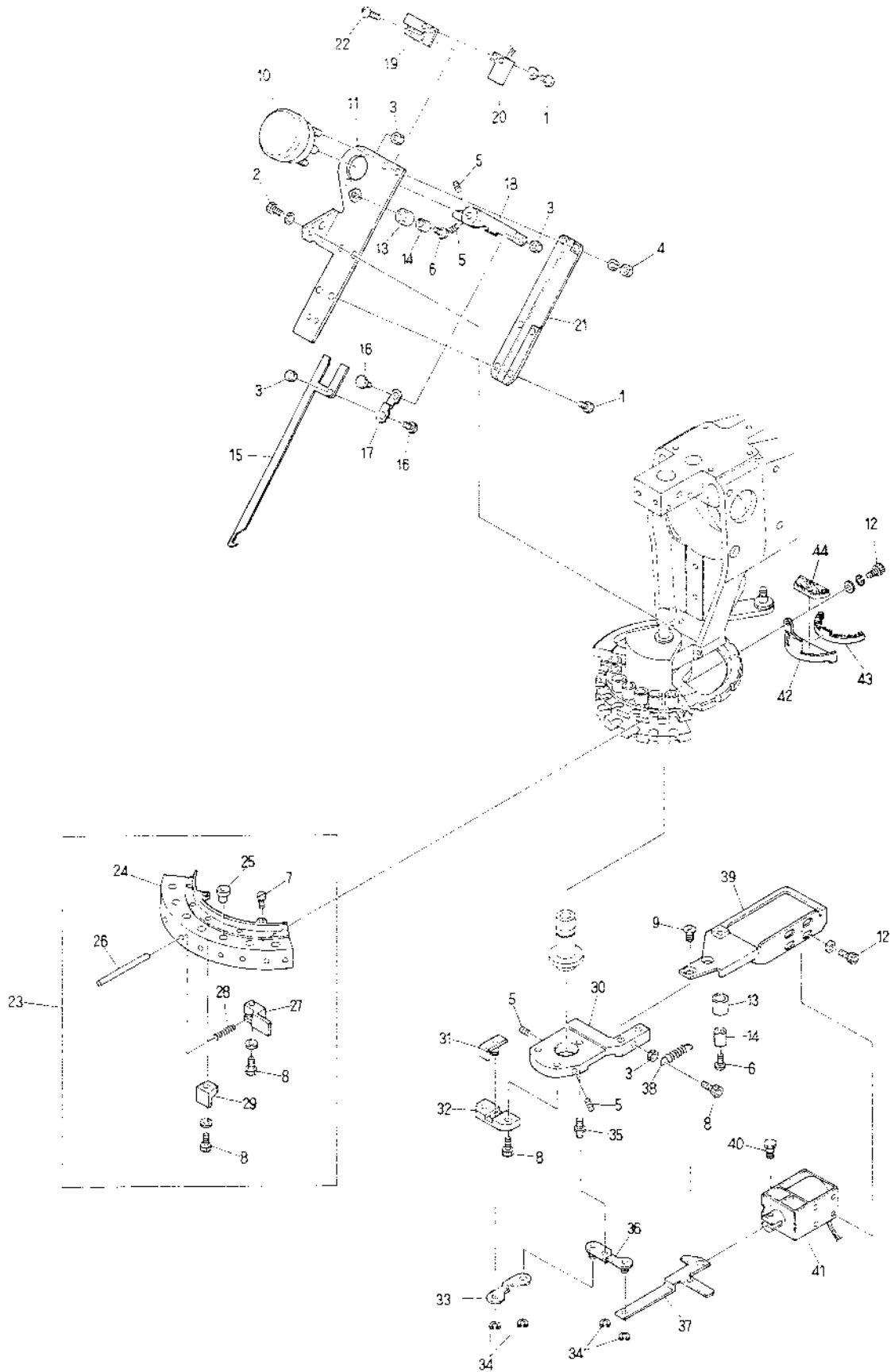



⑮ Thread cutting mechanism II

(N-needle O'ty)

ITEM	PART No.	LIST No.	DESCRIPTION	Q'TY	REMARK
1			Truss screw M3×5		
2			Hex. socket bolt M4×12		
3			Hex. nut M4		
4			Hex. nut M3		
5			Hex. socket set screw M4×5		
6			Truss screw M4×18		
7			Set screw (SM9.64 40)		
8			Hex. socket bolt M4×10		
9			Pan screw M4×8		
10	95607	A9056007	Rotary solenoid	1	
11	2708L00	KL270080	Thread away base	1	
12			Hex. socket bolt M3×6		
13	2715L00	KL270150	Eccentric cover	2	
14	2714L00	KL270140	Stopper eccent	2	
15	2710L00	KL270100	Thread away hook	1	
16	2713L00	KL270130	Lever connecting pin	2	
17	2712L00	KL270120	Connecting plate	1	
18	2711L00	KL270110	Thread away solenoid lever	1	
19	2726L00	KL270260	Switch stay	1	
20	95228	A9052028	Limit switch (RS 603)	1	
21	2709L00	KL270090	Thread away hook guide	1	
22			Truss screw M3×10		
23	2776C01	KC270761	Thread support apron UF Assy (5)	1	
	2776G	KG270760	Thread support apron US Assy (7)	1	
24	2728C03	KC270283	Thread support apron (5)	1	
	2728G02	KG270282	Thread support apron (7)	1	
25	2353F	KF230530	Take up lever ceramic	N×1	
26	2731G	KG270310	Thread support pin (7)	N×1	
27	2730C01	KC270301	Thread support clamp	N×1	
28	2727C01	KC270271	Support spring	N×1	
29	2729C02	KC270292	Thread support block	N×1	
30	2700L00	KL270000	Fixing base	1	
31	2702L00	KL270020	Thread support slider	1	
32	2701L00	KL270010	Slide base	1	
33	2703L00	KL270030	Driving plate	1	
34	91207	A9012127	E-ring	4	
35	2704L00	KL270040	Lever turret pin	1	
36	2706L00	KL270060	Solenoid lever	1	
37	2708L00	KL270080	Lever connecting plate	1	
38	2740C	KC270400	Thread support lever spring	1	
39	2707L00	KL270070	Solenoid stay	1	
40	2710C01	KC270101	Solenoid pin	1	
41	95618	A9056018	Keep solenoid	1	
42	2728L00	KL270280	Thread hanger plate (5)	1	





16 Thread cutting mechanism III

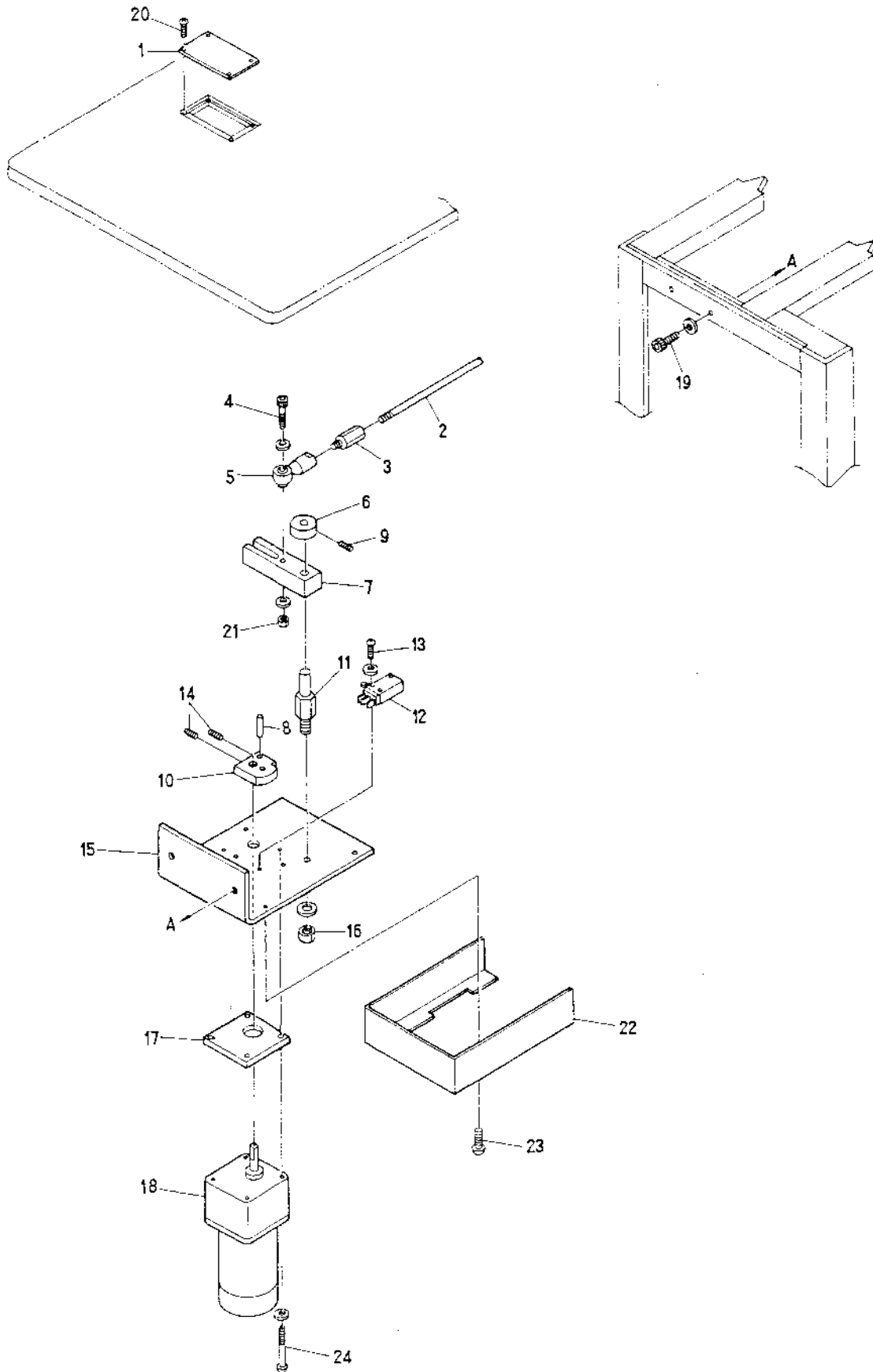

⑩ Thread cutting mechanism III

ITEM	PART No.	LIST No.	DESCRIPTION	QTY	REMARK
1	27B40	KC271440	Drive service cover	1	
2	98410	KC330410	Lock connecting rod	1	
3	23510	KC330510	Hex. connecting bar (L)	1	
4			Hex. socket bolt M5×20		
5	91202	A9912002	Uniball joint RB 6LS	1	
6	38180	KC330180	Collar	1	
7	27B40	KC271140	Motor lever	1	
8	27A5X00	KN272350	Drive pin	1	
9			Hex. socket set screw M5×6		
10	27B7C02	KC271172	Drive cam	1	
11	27B5C01	KC271151	Motor lever turret shaft	1	
12	95205	A9052005	Micro switch V-OIL 2255	1	
13			Screw M3×15 M3×20		
14			Hex. socket set screw M5×8		
15	27B6C02	KC271162	Motor bracket	1	
16			Hex. nut M8		
17	27E30	KC271430	Motor spacer	1	
18	96826	A9065026	Motor RM H6A8FEAA(6RH-036)	1	
19			Hex. socket bolt M8×30		
20			Flush screw M4×6		
21			Hex. nut M8		
22	27H1N02	KN271712	Motor bracket cover	1	
23			Truss screw M3×6		
24			Pan screw M5×55		

# I N D E X

LIST No.	PART No.	PAGENO.	ITEM	LIST No.	PART No.	PAGENO.	ITEM
1PU02520	3A00010	17	16	EAN016A1	51H3LAU	27	1
A9010001	91001	13	37	EAN016A2	51H4CAU	27	13
A9010009	91009	11	10	EAN020A3	51J5UAU	27	14
A9010017	91017	5	5	EAN021A3	51J6CAU	27	14
A9010017	91017	17	5	EAN022A3	51J7CAU	27	14
A9011021	91121	7	22	EBN00560	55T0000	27	11
A9011022	91122	7	23	EBN00570	55T0010	27	9
A9011023	91123	7	21	EBN00580	55T0020	27	5
A9011049	91149	13	5	EBN00590	55T0030	27	4
A9011063	91163	23	14	EBN00600	55T0040	27	6
A9011063	91163	25	14	EBN00610	55T0050	27	12
A9011079	91179	23	25	EBN00620	55T0060	27	7
A9012001	91201	13	19	EBN00630	55T0070	27	8
A9012002	91202	13	28	EBN00640	55T0080	27	10
A9012002	91202	33	5	EBN00650	55T0090	9	6
A9012003	91203	7	58	EBN00660	55T0100	13	3
A9012005	91205	7	58	EBN00670	55T0110	27	21
A9012007	91207	5	34	EBN00680	55T0120	27	22
A9012008	91208	3	9	EBN00690	55T0130	27	23
A9012027	91227	5	57	EBN00700	55T0140	27	24
A9012052	91252	23	27	EBN00710	55T0150	27	25
A9012052	91252	25	18	FA911096	EE99342	27	32
A9012055	91255	13	38	HH120900	1290H	15	13
A9012114	912B4	29	27	HH330281	3328HC1	13	1
A9012127	912C7	31	34	HH330620	3362H	13	6
A9012143	912E3	13	39	HH330670	3367H	13	34
A9012150	912F0	13	8	HH330810	3381H	13	13
A9013045	91345	29	21	HH481931	48J3HC1	21	11
A9014063	91463	5	60	HH481931	48J3HC1	25	9
A9020098	92098	23	10	HH481970	48J7H	23	12
A9020098	92098	25	7	HH481970	48J7H	25	15
A9020116	920B6	13	3	HH481980	48J8H	23	16
A9020120	920C0	13	2	HH481980	48J8H	25	11
A9052005	95205	33	12	HH481991	48J9HC1	23	23
A9052024	95224	23	19	HH481991	48J9HC1	25	21
A9052024	95224	25	26	HH482110	48L1H	23	24
A9052026	95226	23	2	HH482110	48L1H	25	20
A9052026	95226	25	23	HP231290	23D9PC0	7	29
A9052028	95228	31	20	HP231301	23D9PC1	7	27
A9056007	95607	31	10	HP231310	23D1PC0	7	24
A9056008	95608	29	2	HP231330	23D3PC0	11	9
A9056011	95611	13	24	HP231340	23D4PC0	7	55
A9056012	95612	29	1	HP231370	23D7PC0	7	26
A9056013	95613	31	41	HP231390	23D9PC0	5	13
A9065029	96526	33	18	HP240020	24C2PC0	11	1

# I N D E X

LIST No.	PART No.	PAGE No.	ITEM	LIST No.	PART No.	PAGE No.	ITEM
HP 2 4 1 1 1 0	24B1P00	9	2	KC 2 2 0 2 1 0	22210	5	4 0
HP 2 4 1 1 3 0	24B3P00	1 1	1 9	KC 2 2 0 6 4 1	2264001	2 6	2 3
HP 2 4 1 1 4 0	24B4P00	1 1	1 9	KC 2 5 0 4 7 1	2547001	5	5 5
HP 2 4 1 1 5 0	24B5P00	9	1 1	KC 2 5 0 4 8 1	2548001	5	5 4
HP 2 4 1 1 6 0	24B6P00	9	3	KC 2 7 0 1 0 1	2710001	3 1	4 0
HP 2 4 1 1 7 0	24B7P00	9	9	KC 2 7 0 2 7 1	2727001	3 1	2 8
HP 2 4 1 1 9 0	24B9P00	9	7	KC 2 7 0 2 8 3	2728003	3 1	2 4
HP 2 4 1 2 1 0	24C1P00	1 1	1 8	KC 2 7 0 2 9 2	2729002	3 1	2 9
HP 2 4 1 3 7 1	24D7P01	9	4	KC 2 7 0 3 0 1	2730001	3 1	2 7
HP 2 4 1 3 9 0	24D9P00	9	5	KC 2 7 0 4 0 0	27400	3 1	3 8
HP 2 4 1 4 0 0	24E0P00	9	1 3	KC 2 7 0 7 6 1	2776001	3 1	2 3
HP 2 4 1 4 1 0	24E1P00	9	1 2	KC 2 7 0 9 4 0	27940	2 9	1 3
HP 2 4 1 4 5 0	24E5P00	9	8	KC 2 7 0 9 5 0	27950	2 9	2 0
HP 2 4 1 4 7 0	24E7P00	9	1 0	KC 2 7 0 9 6 0	27960	2 9	1 4
HP 2 5 0 0 5 0	2505P00	9	1 7	KC 2 7 0 9 7 0	27970	2 9	2 2
HP 2 5 0 5 8 1	2558P01	9	1 5	KC 2 7 0 9 8 0	27980	2 9	1 9
HP 3 2 1 1 4 0	32B4P00	1 7	7	KC 2 7 1 0 0 3	27A00	2 9	1 2
HP 3 3 1 5 3 1	33F3P01	1 3	2 5	KC 2 7 1 0 2 1	27A2001	2 9	1 1
HP 3 3 1 5 5 0	33F5P00	1 3	2 2	KC 2 7 1 0 3 1	27A3001	2 9	1 0
HP 3 3 1 5 5 0	33F6P00	1 3	3 3	KC 2 7 1 0 4 1	27A4001	2 9	9
HP 3 3 1 5 7 0	33F7P00	1 3	1 4	KC 2 7 1 0 7 0	27A70	2 9	2 9
HP 3 3 1 5 8 0	33F8P00	1 3	1 6	KC 2 7 1 1 2 0	27B20	2 9	2 8
HP 3 3 1 5 9 0	33F9P00	1 3	1 7	KC 2 7 1 1 3 0	27B30	2 9	3 0
HP 3 3 1 6 0 0	33G0P00	1 3	2 3	KC 2 7 1 1 4 0	27B40	3 3	7
HP 3 3 1 6 6 0	33G6P00	1 3	2 0	KC 2 7 1 1 5 1	27B5001	3 3	1 1
HP 3 3 1 9 4 0	33J4P00	1 3	9	KC 2 7 1 1 6 2	27B6002	3 3	1 5
HP 3 3 1 9 5 0	33J5P00	1 3	3 6	KC 2 7 1 1 7 2	27B7002	3 3	1 0
HP 3 3 1 9 6 0	33J6P00	1 3	1 0	KC 2 7 1 1 8 0	27B80	2 9	3 5
HP 4 8 2 9 1 0	48T1P00	2 5	8	KC 2 7 1 1 9 1	27B9001	2 9	1 8
HP 4 8 2 9 4 0	48T4P00	2 3	1 1	KC 2 7 1 2 0 1	27C0001	2 9	1 7
HP 4 8 2 9 4 0	48T4P00	2 5	6	KC 2 7 1 2 1 1	27C1001	2 9	1 6
HP 4 8 2 9 5 0	48T5P00	2 3	6	KC 2 7 1 2 2 0	27C20	2 9	1 5
HP 4 8 2 9 5 0	48T5P00	2 5	5	KC 2 7 1 4 3 0	27E30	3 3	1 7
HP 4 8 2 9 8 0	48T8P00	2 3	2 6	KC 2 7 1 4 4 0	27E40	3 3	1
HP 4 8 2 9 8 0	48T8P00	2 5	1 9	KC 2 7 1 9 4 0	27J40	2 9	7
HP 4 8 2 9 9 0	48T9P00	2 3	1 5	KC 2 7 1 9 5 0	27J50	2 9	6
HP 4 8 2 9 9 0	48T9P00	2 5	1 2	KC 2 7 1 9 6 0	27J60	2 9	3
HP 4 8 3 1 1 1	48V1P01	2 5	1	KC 2 7 1 9 7 0	27J70	2 9	8
HP 4 8 3 3 7 0	48X7P00	2 3	3	KC 3 2 0 5 9 0	32590	1 7	1
HP 4 8 3 3 7 0	48X7P00	2 5	2	KC 3 3 0 1 7 0	33170	1 3	2
HP 4 8 3 3 9 0	48X9P00	2 3	4	KC 3 3 0 1 8 0	33180	3 3	6
HP 7 1 0 7 9 0	7179P00	1 5	7	KC 3 3 0 4 1 0	33410	7	1 5
HQ 7 4 1 F 3 0	740F300	1 3	3 2	KC 3 3 0 4 1 0	33410	3 3	2
KC 1 1 0 9 1 0	11910	3	2 4	KC 3 3 0 5 1 0	33510	1 3	2 7
KC : 2 0 8 4 1	1284001	3	1 4	KC 3 2 0 5 1 0	33510	3 3	3

# I N D E X

LIST No.	PART No.	PAGENO.	ITEM	LIST No.	PART No.	PAGENO.	ITEM
KC 4 8 0 1 5 0	4815C	2 1	5	KF 2 4 0 2 0 0	2420F0C	1 1	3
KC 4 8 0 3 5 0	4835C	2 1	3	KF 2 4 0 4 2 0	2442F	1 1	1 3
KC 5 1 0 2 4 0	5124C	1 9	1 1	KF 2 4 0 4 5 0	2445F	1 1	5
KC 5 3 0 2 3 0	5323C00	2 7	1 9	KF 2 4 0 4 6 0	2446F	1 1	1 2
KC 5 3 0 2 4 0	5324C00	2 7	1 7	KF 2 4 0 4 7 0	2447F	1 1	1 1
KC 3 3 0 3 1 0 3 8 0	3331C	7	5 6	KF 2 4 0 4 8 0	2448F	1 1	8
KF 2 2 0 1 3 0	2213F	5	1 1	KF 2 4 0 4 9 0	2449F	1 1	7
KF 2 2 0 2 3 0	2223F	5	4 4	KF 2 4 0 6 1 0	2461F	1 1	1 4
KF 2 2 0 2 7 0	2227F	5	2 7	KF 2 4 0 9 0 0	2490F	1 5	5
KF 2 2 0 2 9 0	2229F	5	3 7	KF 2 4 0 9 3 1	2493F01	9	1 5
KF 2 2 0 3 1 0	2231F	5	4 9	KF 2 5 0 9 0 0	2590F	5	4 2
KF 2 2 0 3 7 0	2237F	5	5 2	KF 3 3 0 3 8 1	3338F01	7	1 4
KF 2 2 0 4 1 0	2241F	5	5 1	KF 5 3 0 1 1 0	5311F	2 7	1 8
KF 2 2 0 4 6 0	2246F	5	1 9	KF 5 3 0 1 2 0	5312F	2 7	1 8
KF 2 2 0 4 7 0	2247F	5	2 6	KF 5 3 0 1 5 0	5315F	2 7	2 0
KF 2 2 0 4 8 0	2248F	5	3 5	KF 5 3 0 1 6 0	5316F	2 7	1 5
KF 2 2 0 7 5 0	2275F00	5	4 9	KF 5 3 0 1 7 0	5317F	2 7	1 6
KF 2 3 0 0 1 0	2301F	7	4 2	KF 5 4 0 3 5 0	5435F	1 7	9
KF 2 3 0 1 5 0	2315F	7	5 9	KF 7 1 0 2 8 0	7128F	1 5	6
KF 2 3 0 1 8 0	2318F	7	4 3	KG 1 2 0 6 6 2	1266G02	3	2
KF 2 3 0 2 1 0	2321F	7	4 5	KG 2 1 0 9 1 1	2191G01	5	5 6
KF 2 3 0 2 3 0	2323F	7	4 9	KG 2 3 0 0 2 0	2302G	7	4 4
KF 2 3 0 2 4 0	2324F	7	5 0	KG 2 3 0 6 1 0	2361G	7	1 7
KF 2 3 0 2 5 0	2325F	7	5 1	KG 2 4 1 0 2 0	24A2G	9	1
KF 2 3 0 3 2 0	2332F	7	2	KG 2 4 1 0 3 1	24A3G01	1 5	4
KF 2 3 0 4 2 0	2342F	5	3 0	KG 2 7 0 2 8 2	2728G02	3 1	2 4
KF 2 3 0 4 5 0	2345F	7	2 8	KG 2 7 0 3 1 0	2731G	3 1	2 6
KF 2 3 0 4 8 0	2348F	7	3 0	KG 2 7 0 7 0 0	2776G	3 1	2 3
KF 2 3 0 5 0 0	2350F	7	3 7	KG 3 3 0 1 5 0	3315G	1 3	1 8
KF 2 3 0 5 1 2	2351F02	7	3	KG 7 1 1 1 7 3	71B7G03	1 5	3
KF 2 3 0 5 2 1	2352F01	7	4	KL 2 1 0 0 0 0	2100L00	5	2 3
KF 2 3 0 5 8 0	2358F	7	4 0	KL 2 1 0 0 0 T	2100L0T	5	2 3
KF 2 3 0 5 8 0	2358F	3 1	2 5	KL 2 1 0 0 1 0	2101L00	5	2 3
KF 2 3 0 6 2 0	2362F	1 3	3 3	KL 2 1 0 0 1 T	2101L0T	5	2 3
KF 2 3 0 6 3 0	2363F	7	1 0	KL 2 1 0 1 2 0	2112L00	2 9	2 3
KF 2 3 0 6 3 0	2363F	1 3	2 6	KL 2 1 0 1 3 0	2113L00	5	4 7
KF 2 3 0 6 4 0	2364F	7	1 2	KL 2 1 0 1 4 0	2114L00	5	1 7
KF 2 3 0 6 4 0	2364F	2 9	3 1	KL 2 2 0 0 0 0	2200L00	5	1 6
KF 2 3 0 6 5 0	2365F	7	9	KL 2 2 0 0 1 0	2201L00	5	2 4
KF 2 3 0 6 6 1	2366F01	7	1 9	KL 2 2 0 0 2 0	2202L00	5	2 9
KF 2 3 0 6 7 0	2367F	7	2 0	KL 2 2 0 0 3 0	2203L00	5	1 5
KF 2 3 0 9 1 0	2391F	7	4 7	KL 2 2 0 0 4 0	2204L00	5	6
KF 2 3 0 9 2 0	2392F	7	4 6	KL 2 2 0 0 5 0	2205L00	5	2 1
KF 2 3 0 9 3 0	2393F	7	4 8	KL 2 2 0 0 6 0	2206L00	5	2 5
KF 2 4 0 0 3 0	2403F	7 1	2	KL 2 2 0 0 7 0	2207L00	5	3 6



# I N D E X

LIST No	PART No	PAGENO	ITEM	LIST No	PART No	PAGENO	ITEM
KL 2 2 0 0 8 0	2208L00	5	1 2	KL 2 7 0 2 9 0	2729L00	3 1	4 2
KL 2 2 0 0 9 0	2209L00	5	4	KL 2 7 0 3 0 0	2730L00	3 1	4 3
KL 2 2 0 1 0 0	2210L00	5	1	KL 2 7 0 3 1 0	2731L00	3 1	4 4
KL 2 2 0 1 1 0	2211L00	5	3	KL 2 7 0 3 2 0	2732L00	3 1	4 3
KL 2 2 0 1 2 0	2212L00	5	4 1	KL 2 7 0 3 3 0	2733L00	3 1	4 4
KL 2 2 0 1 3 0	2213L00	5	1 4	KL 3 2 0 0 0 0	3200L00	1 7	6
KL 2 2 0 1 4 0	2214L00	5	2 0	KL 3 2 0 0 2 0	3202L00	1 7	3
KL 2 2 0 1 5 0	2215L00	5	8	KN 2 3 0 4 1 0	2341N00	5	3 1
KL 2 3 0 0 0 0	2300L00	7	1	KN 2 3 0 4 3 0	2343N00	5	3 3
KL 2 3 0 0 1 0	2301L00	7	3 4	KN 2 7 1 6 0 1	2700N01	2 9	2 5
KL 2 3 0 0 2 0	2302L00	7	3 2	KN 2 7 1 6 5 1	2705N01	2 9	4
KL 2 3 0 0 3 0	2303L00	7	3 3	KN 2 7 1 6 6 2	2706N02	2 9	5
KL 2 3 0 0 5 0	2305L00	7	5 4	KN 2 7 1 7 1 2	2711N02	3 3	2 2
KL 2 3 0 0 7 0	2307L00	7	3 9	KN 2 7 1 8 9 0	2719N00	2 9	2 4
KL 2 3 0 0 8 0	2308L00	7	3 9	KN 2 7 2 3 5 0	2725N00	3 3	8
KL 2 3 0 1 1 0	2311L00	7	5 3	KN 2 7 2 5 4 0	2724N00	2 9	4 3
KL 2 3 0 1 2 0	2312L00	7	5 3	KN 4 8 0 0 6 1	4803N01	2 3	8
KL 2 3 0 1 3 0	2313L00	7	5 2	KN 4 8 0 0 6 1	4806N01	2 5	3
KL 2 3 0 1 4 0	2314L00	7	3 1	KN 4 8 0 4 2 0	4842N00	2 1	2
KL 2 3 0 1 7 0	2317L00	7	3 5	KN 4 8 2 0 0 0	4800N00	2 3	2 1
KL 2 3 0 1 9 0	2319L00	7	4 1	KN 4 8 2 0 1 0	4801N00	2 3	1 3
KL 2 3 0 2 0 0	2320L00	7	4 1	KN 4 8 2 8 7 0	4857N00	2 3	5
KL 2 3 0 2 1 0	2321L00	7	6 0	KN 4 8 2 8 8 0	4858N00	2 3	7
KL 2 3 0 2 2 0	2322L00	7	6 0	KN 4 8 3 4 0 0	4800N00	2 3	2 0
KL 2 5 0 0 1 0	2501L00	9	1 4	KN 4 8 3 4 5 0	4855N00	2 3	2 2
KL 2 5 0 0 4 0	2504L00	5	7	KU 1 2 0 8 0 0	1280U00	3	1 3
KL 2 5 0 0 5 0	2505L00	5	5 9	KU 1 4 0 5 5 0	1455U00	3	1 5
KL 2 7 0 0 0 0	2700L00	3 1	3 0	KU 1 5 1 6 2 3	1502U03	3	1
KL 2 7 0 0 1 0	2701L00	3 1	3 2	KU 1 5 1 7 7 0	1507U00	3	6
KL 2 7 0 0 2 0	2702L00	3 1	3 1	KU 1 6 1 6 2 2	1602U02	3	5
KL 2 7 0 0 3 0	2703L00	3 1	3 3	KU 3 1 0 1 0 0	3110U00	1 9	7
KL 2 7 0 0 4 0	2704L00	3 1	3 5	KU 3 1 0 1 5 2	3115U02	1 9	1 3
KL 2 7 0 0 5 0	2705L00	3 1	3 8	KU 3 1 0 1 6 1	3116U01	1 7	1 0
KL 2 7 0 0 6 0	2706L00	3 1	3 7	KU 3 1 2 7 2 0	3120U00	1 9	4
KL 2 7 0 0 7 0	2707L00	3 1	3 9	KU 3 1 2 7 3 0	3123U00	1 9	1
KL 2 7 0 0 8 0	2708L00	3 1	1 1	KU 3 1 2 7 4 1	3124U01	1 9	5
KL 2 7 0 0 9 0	2709L00	3 1	2 1	KU 3 1 2 7 5 1	3125U01	1 9	6
KL 2 7 0 1 0 0	2710L00	3 1	1 5	KU 3 1 2 7 6 1	3126U01	1 7	1 7
KL 2 7 0 1 1 0	2711L00	3 1	1 8	KU 3 1 5 2 5 0	3152U00	1 9	1 4
KL 2 7 0 1 2 0	2712L00	3 1	1 7	KU 3 3 1 5 2 0	3315U00	1 3	2 1
KL 2 7 0 1 3 0	2713L00	3 1	1 6	KU 3 3 1 7 1 1	3317U01	1 3	3 0
KL 2 7 0 1 4 0	2714L00	3 1	1 4	KU 3 3 1 7 2 1	3318U01	1 3	3 1
KL 2 7 0 1 5 0	2715L00	3 1	1 3	KU 3 3 1 7 3 0	3319U00	1 3	2 9
KL 2 7 0 2 6 0	2726L00	3 1	1 9	KU 3 3 1 7 4 0	3324U00	1 3	7
KL 2 7 0 2 8 0	2728L00	3 1	4 2	KU 3 3 1 7 5 0	3325U00	1 3	4 0

# I N D E X

LIST No.	PART No.	PAGENO.	ITEM	LIST No.	PART No.	PAGENO.	ITEM
KU 3 3 1 7 6 0	33H6U00	1 3	4 1	MT 5 1 0 6 8 1	5168T01	1 5	8
KU 3 3 1 9 0 0	33J9U00	1 3	1 0	MT 5 1 0 7 9 1	5179T01	1 5	9
KU 3 3 1 9 1 0	33J1U00	1 3	4	MT 5 1 1 2 7 0	5107T00	2 7	2
KU 3 3 1 9 3 0	33J9U00	1 3	1 2	WW 3 1 0 3 0 0	3130W00	1 7	1 2
KU 4 6 0 2 7 0	4627U00	2 2	1 7	WW 3 1 0 3 1 0	3131W00	1 7	1 4
KU 4 6 0 2 7 0	4627U00	2 5	2 4				
KU 4 6 0 3 2 1	4632U01	2 5	2 2				
KU 4 6 0 3 4 2	4634U02	2 3	1				
KU 4 6 0 3 6 0	4636U00	2 5	2 7				
KU 4 6 0 4 6 1	4646U01	2 3	1 8				
KU 4 6 0 5 1 1	4651U01	2 1	1				
KU 4 7 0 1 0 0	4710U00	2 5	1 3				
KU 4 7 0 1 5 1	4715U01	2 1	9				
KU 4 7 0 4 6 0	4746U00	2 5	1 7				
KU 4 8 0 1 3 0	4813U00	2 5	1 6				
KU 4 8 1 0 5 0	48A5U00	2 1	4				
KU 4 8 3 1 8 0	48V8U00	2 5	4				
KU 4 8 3 4 4 0	48Y4U00	2 3	9				
KU 4 9 0 1 8 0	4918J00	2 5	1 0				
KU 4 9 0 7 0 0	4970U00	2 1	1 3				
KU 5 1 0 4 2 0	5142U00	9	1 8				
KU 5 1 1 2 1 1	51C1U01	2 7	3				
KJ51076102520	5175C	1 5	1				
KJ51087102520	5187N00	1 5	1				
MA 1 4 0 3 8 0	1438A	3	3				
MA 1 4 0 5 3 0	1453A	3	1 7				
MA 1 4 0 5 7 0	1457A	3	1 6				
MA 1 4 0 5 8 0	1458A	3	1 8				
MA 1 4 0 6 9 0	1469A	3	4				
MA 1 4 0 7 4 0	1474A	3	7				
MA 1 4 0 7 5 0	1475A	3	1 1				
MA 1 4 0 7 6 0	1476A	3	1 0				
MA 1 4 0 7 8 0	1478A	3	8				
MA 1 4 0 9 6 0	1496A00	3	1 2				
MA 2 2 0 5 1 0	2251A	5	4 5				
MA 2 5 0 1 3 1	2513A01	5	4 3				
MT 3 1 0 1 3 0	3113T00	1 9	8				
MT 3 1 4 4 1 0	31DET00	1 9	1 0				
MT 3 1 4 4 2 0	31DET00	1 9	9				
MT 4 6 0 2 4 0	4624T00	2 3	1 8				
MT 4 6 0 2 4 0	4624T00	2 5	2 5				
MT 4 7 0 1 1 0	4711T00	2 1	1 0				
MT 4 8 3 3 6 0	48X8T00	2 1	1 7				
MT 5 1 0 2 1 0	5121T00	1 9	1 2				
MT 5 1 0 6 7 1	5167T01	1 5	1 0				